

Sheet Name	Sheet Number	Sheet Name	Sheet Number
0A_Preface	1	3A_B_Engine_Management_DHE3	42
0B1_BFB_HBFB_HMDB_Armament_List	2	3A_B_Engine_Management_VEP4_7DCT	43
0B3_EJB_Armament_List	3	3A_B_Engine_Management_VEP4_8AT	44
0B4_CJB_Armament_List	4	3B_A_Engine_Thermal_Management	45
1A1_Electrical_Distribution_EJB	5	3B_B_Engine_Thermal_Management	46
1A2_Electrical_Distribution_CJB	6	3C_Transmission_7DCT	47
1A4_Electrical_Distribution_Relays_Control	7	3C_Transmission_8AT	48
1B1_Grounding_Engine_Bay	8	3D_A_Fuel_Supply_Control	49
1B2_Grounding_IP_Roof	9	3D_B_Fuel_Supply_Control	50
1B3_Grounding_Body_Front	10	4A_A_Parking_Assistance	51
1B4_Grounding_Body_Rear_Tailgate	11	4A_B_Parking_Assistance	52
1C_Power_Generating	12	4B_Visual_Assistance	53
1D_Diagnostics	13	4C_Keyless_Vehicle_Antenna	54
1E1_Flexray_Backbone	14	5A1_A_Climate_Control	55
1E2_Body_CAN	15	5A2_B_Climate_Control_Internal	56
1E3_Body_Exposed_CAN	16	5B1_Power_Seat	57
1E4_Chassis_CAN1	17	5B2_A_Power_Seat_Driver_Internal	58
1E5_Chassis_CAN2	18	5B2_B_Power_Seat_Driver_Internal	59
1E6_Passive_Safety_CAN	19	5B3_Power_Seat_Passenger_Internal	60
1E7_A_Propulsion_CAN	20	6A1_Power_Door_Driver	61
1E7_B_Propulsion_CAN	21	6A2_Power_Door_Passenger	62
1E8_CAN_FD	22	6A3_Power_Door_Rear_Left	63
1E10_Connectivity_CAN	23	6A4_Power_Door_Rear_Right	64
1E11_Private_CAN	24	6A5_Power_Door_Tailgate	65
1E13_Ethernet	25	6B_Roof_Manoeuvring	66
1E14_ECM_LIN	26	6C1_Windscreen_Defroster_Control	67
1E15_CEM_LIN	27	6C2_Windscreen_Cleaning_Control	68
1E16_Comfort_LIN	28	6D_Voltage_Outlet	69
1E19_ETC_Calibration	29	6E_Steering_Wheel	70
1E20_A_ETC_Tadapter_Harness	30	6F_Accessories	71
1E20_B_ETC_Tadapter_Harness	31	7A1_External_Amplifier	72
2A1_Braking_VDDM_F-LD	32	7A2_Infotainment	73
2A1_Braking_VDDM_F-TE	33	7B1_Telematics	74
2A2_Braking_BBM	34	7B2_ECALL	75
2B_Collision_Avoidance	35	7C_Display	76
2C1_A_Supplementary_Restraint_System	36	8A1_Exterior_Lights_Front	77
2C1_B_Supplementary_Restraint_System	37	8A2_Exterior_Lights_Rear	78
2D_Power_Steering	38	8B1_Interior_Lights_Overhead	79
3A_A_Engine_Management_DHE3	39	8B2_Interior_Lights_Ambient	80
3A_A_Engine_Management_VEP4_7DCT	40	9C_Energy_Management_High_Voltage	81
3A_A_Engine_Management_VEP4_8AT	41		

GEELY	Document title KX11_MP1_base_B7	
	0A_Preface	
	Document Type DRAW/ELSY	Release Status Released
	Document No 8889755035	Edited January/19/2021
	Issue 007	Page No 1/83

The copying, distribution and utilization of this document as well as the communication of its contents to others without expressed authorization is prohibited. Offenders will be held liable for payment of damages. All rights reserved in the event of the grant of a patent, utility model or ornamental design registration.

0B1 BFB / HBFB / HMDB Armament List

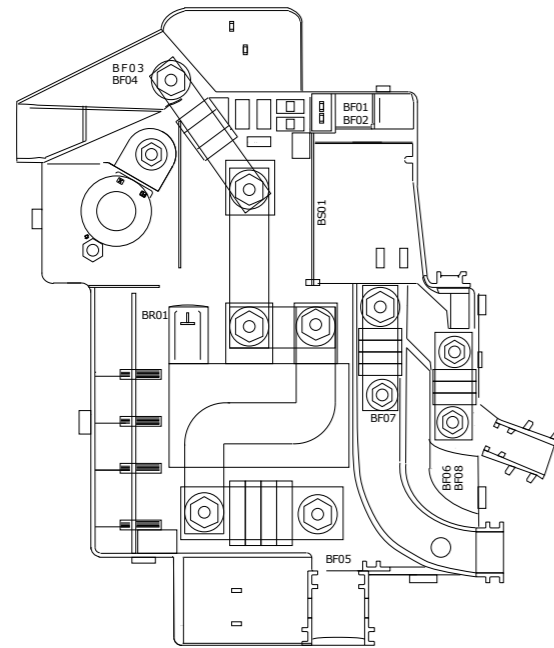

1. Fuse arrangement BFB

Fuse	Component	Logic	KX11	Type	Rate (A)	Variant
BF01	4/221 BATTERY MONITORING SENSOR BMS	KL30	X	MCase	15	BD01
BF02	Spare	KL30		MCase		
BF03	Spare	KL30		Mega		
BF04	6/25 STARTER MOTOR	KL30	X	Mega	400	BD01
BF05	6/26 ALTERNATOR ACM	KL30	X	Mega	250	BD01
BF06	15/49 ENGINE JUNCTION BOX	KL30	X	Midi	100	BD01
BF07	6/163 ELECTRIC POWER ASSISTED STEERING EPAS	KL30	X	Midi	125	BD01
BF08	15/50 CENTRAL JUNCTION BOX	KL30	X	Midi	125	BD01
BF08	Spare	KL30		Midi		

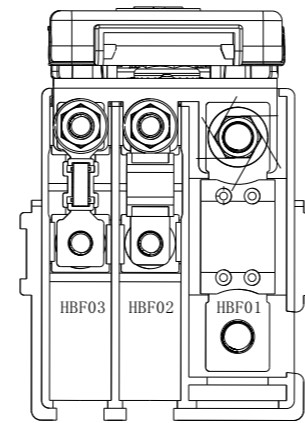

2. Fuse arrangement HBFB

Fuse	Component	Logic	KX11 HEV	Type	Rate (A)	Variant
HBF01	15/44 HYBRID MAIN DISTRIBUTION BOX 1	KL30	X	MEGA	400	BD06
HBF02	15/50 CENTRAL JUNCTION BOX	KL30	X	MIDI	125	BD06
HBF03	4/221.1 BATTERY MONITORING SENSOR BMS	KL30	X	MINI	5	BD06

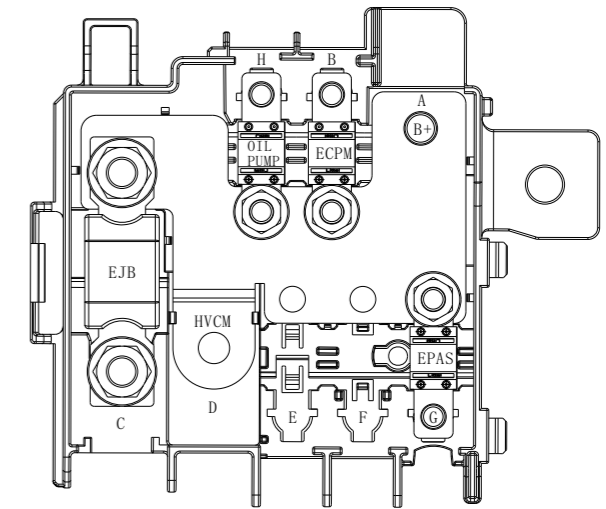

3. Fuse arrangement HMDB

Fuse	Component	Logic	KX11 HEV	Type	Rate (A)	Variant
A	Battery B+	KL30	X	/	/	BD06
B	4/225.1 ENGINE COOLANT PUMP MODULE ECPM	KL30	X	MIDI	60	BD06
C	15/49 ENGINE JUNCTION BOX	KL30	X	MEGA	250	BD06
D	4/889 HIGH VOLTAGE CONVERTER MODULE HVCM	KL30	X	/	/	BD06
E	Spare	KL30	/	/	/	/
F	Spare	KL30	/	/	/	/
G	6/163 ELECTRIC POWER ASSISTED STEERING EPAS	KL30	X	MIDI	100	BD06
H	6/179 TRANSMISSION ELECTRICAL OIL PUMP	KL30	X	MIDI	50	BD06

The copying, distribution and utilization of this document as well as the communication of its contents to others without expressed authorization is prohibited. Offenders will be held liable for payment of damages. All rights reserved in the event of the grant of a patent, utility model or ornamental design registration.

GEELY

Document title KX11_MP1_base_B7

0B1_BFB_HBFB_HMDB_Armament_List

Document Type
DRAW/ELSY

Release Status
Released

Document No
8889755035

Edited
June/21/2021

Issue
007

Page No
2/83

0B3 EJB Armament List

1. Fuse arrangement EJB

Fuse	Component	Logic	KX11 base	KX11 HEV	Type	Rate (A)	Variant
EF01	Spare	KL30			Mcase		
EF02	6/29 RADIATOR COOLING FAN MOTOR Low speed	KL30	X		Mcase	40	EZ03
EF03	Spare	KL30			Mcase		
EF04	6/1 WINDSCREEN WIPER MOTOR WWM	KL30	X	X	Mcase	30	ALL
EF05	Spare	KL30			Micro		
EF06	Spare	KL30			Micro		
EF07	4/163 VEHICLE DYNAMICS DOMAIN MASTER VDDM	KL30	X	X	Mcase	40	ALL
EF08	4/163 VEHICLE DYNAMICS DOMAIN MASTER VDDM	KL30	X		Mcase	60	EA01
EF08	4/163 VEHICLE DYNAMICS DOMAIN MASTER VDDM	KL30	X	X	Mcase	40	EA03 EA08
EF09	4/302 BRAKE BOOSTER MODULE BBM	KL30	X	X	Mcase	60	EA03 EA08
EF10	4/889 HIGH VOLTAGE CONVERTER MODULE HVCM	KL30		X	Micro	5	BD06
EF11	1/4 HIGH VOLTAGE BATTERY	KL30		X	Micro	10	BD06
EF12	Relay coil	KL30	X		Micro	5	EZ03
EF13	Spare	KL30			Mcase		
EF14	Spare	KL30			Micro		
EF15	Spare	KL30			Mcase		
EF16	10/2 RH HEADLAMP UNIT	ER10	X	X	Micro	20	ALL
EF17	10/1 LH HEADLAMP UNIT	ER10	X	X	Micro	20	ALL
EF18	Spare	KL30			Mcase		
EF19	Spare	KL30			Mcase		
EF20	Spare	KL30			Mcase		
EF21	HV_Component	ER02		X	Micro3	10	BD06
EF21	HV_Component	ER02		X	Micro3	10	BD06
EF22	Spare	KL30			Micro		
EF23	Spare	KL30			Micro		
EF24	Spare	KL30			Micro		
EF25	Spare	KL30			Mcase		
EF26	Spare	KL30			Micro		
EF27	4/291 FORWARD LOOKING RADAR FLR	ER01	X	X	Micro	5	SJ02
EF28	10/1 LH HEADLAMP UNIT	ER01	X	X	Micro	20	ALL
EF29	4/351 Front Side Radar Right FSRR	KL30	X		Micro3	5	UB02
EF29	4/352 Front Side Radar Left FSRL	KL30	X		Micro3	5	ALL
EF29	7/124 BRAKE PEDAL SENSOR	KL30	X	X	Micro3	5	ALL
EF30	Spare	ER02			Micro		
EF31	Spare	KL30			Micro3		
EF31	Spare	KL30			Micro3		
EF32	Spare	ER15			Micro		
EF33	Spare	KL30			Micro		
EF34	Spare	KL30			Micro		
EF35	10/2 RH HEADLAMP UNIT	ER01	X	X	Micro	20	ALL
EF36	Spare	KL30			Micro3		
EF36	Spare	KL30			Micro3		
EF37	6/195 BATTERY COOLANT WATER PUMP 1	ER02		X	Micro	15	BD06
EF38	4/565 ELECTRONIC TOLL COLLECT MODULE ETCM	ER01	X	X	Micro	5	AS02 & MA10
EF38	4/489 DIGITAL VIDEO RECORDER DVR	KL30			Micro3		
EF39	Spare	KL30			Micro3		
EF39	Spare	KL30			Micro3		
EF40	Spare	ER02			Micro		
EF41	Chassis_Components	ER01	X	X	Micro3	5	ALL
EF41	4/894 PARKING DISTANCE CONTROL MODULE PDCM	ER01	X	X	Micro3	5	LJ02 LV09
EF42	4/176 SUPPLEMENTARY RESTRAINT SYSTEM SRS	ER01	X	X	Micro	5	ALL
EF43	4/178 ELECTRIC DRIVETRAIN COOLANT PUMP EDCP	ER02		X	Micro	20	BD06
EF44	7/51 ACCELERATOR PEDAL SENSOR	ER01	X	X	Micro3	5	ALL
EF44	HEADLAMP Leveling	ER01	X	X	Micro3	5	D802
EF45	Spare	Micro			Micro		
EF46	Spare	KL30			Micro3		
EF46	Spare	KL30			Micro3		
EF47	Spare	KL30			Micro3		
EF47	Spare	KL30			Micro3		
EF48	Spare	KL30			Micro3		
EF48	Spare	KL30			Micro3		
EF49	Spare	KL30			Micro		
EF50	4/890 POWERTRAIN CONTROL MODULE PCM	KL30		X	Micro	15	BD06
EF51	16/10 HORN 1	KL30	X	X	Micro	20	ALL
EF51	16/11 HORN 2	KL30	X	X	Micro	20	ALL
EF52	6/127 FRONT/REAR WINDOW WASHER PUMP	KL30	X	X	Mcase	25	ALL
EF53	Spare	KL30			Micro		
EF54	Spare	KL30			Mcase		
EF55	9/7 HEATED WINDSCREEN	ER03	X		Mcase	40	DJ02
EF56	9/7 HEATED WINDSCREEN	ER03	X		Mcase	40	DJ02
EF57	Spare	KL30			Midi		
EF58	Spare	KL30			Midi		
EF59	Spare	KL30			Midi		
EF60	4/225 ENGINE COOLANT PUMP MODULE ECPM	KL30	X		Midi	60	BD01
EF61	6/29 RADIATOR COOLING FAN MOTOR High speed	KL30	X		Midi	60	EB02
EF61	4/71 ELECTRONIC FAN CONTROL MODULE EFCM	KL30	X	X	Midi	80	EB03
EF62	Spare	KL30			Mcase		
EF63	6/25 STARTER MOTOR	KL30	X		Mcase	30	BD01
EF64	Spare	KL30			Mcase		
EF65	Engine_Components	ER04	X	X	Micro	10	ALL
EF66	ECM Power	ER04	X	X	Micro	20	ALL
EF67	VEP4 Module Valve	ER04	X		Micro	15	CA02
EF68	Spare	ER04			Micro		
EF69	4/46 ENGINE CONTROL MODULE ECM	KL30	X	X	Micro	5	ALL
EF70	94/398 INLINE 7DCT 1	KL30	X		Micro	25	CA14
EF70	4/28 TRANSMISSION CONTROL MODULE TCM	KL30	X		Micro	15	CA02
EF71	Oxygen Sensor	ER04	X	X	Micro3	15	ALL
EF71	Ignition Coil	ER04	X	X	Micro3	15	ALL
EF72	Spare	ER04			Micro3		
EF72	Spare	ER04			Micro3		
EF73	Spare	KL30			Micro		
EF74	94/398 INLINE 7DCT 1	KL30	X		Mcase	30	CA02 CA14
EF74	4/209 TRANSMISSION ACTUATOR CONTROL MODULE TACM	KL30	X		Micro	25	CA14
EF75	94/398 INLINE 7DCT 1	KL30	X		Micro	25	CA14
EF76	94/398 INLINE 7DCT 1	KL30	X		Mcase	30	CA02 CA14
EF76	4/209 TRANSMISSION ACTUATOR CONTROL MODULE TACM	KL30	X		Mcase	30	CA02 CA14

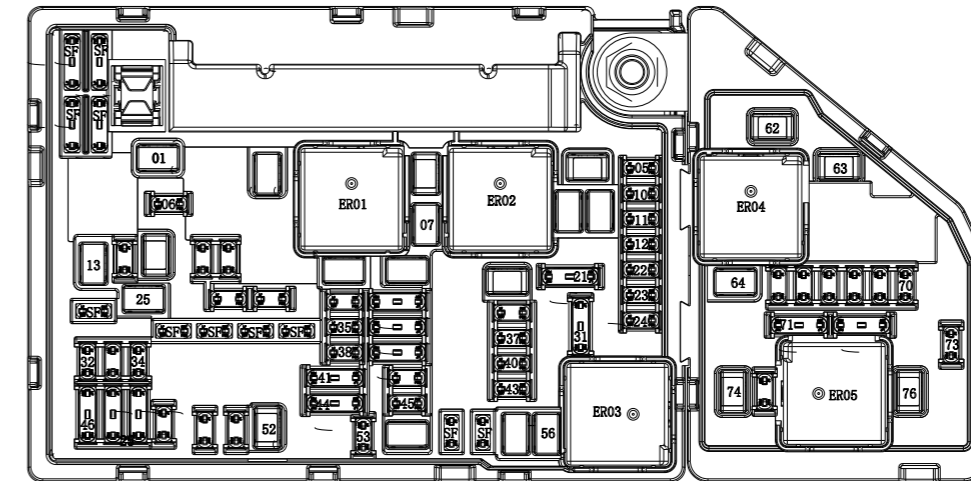

2. Relay arrangement EJB

Relay	Component	KX11 base	KX11 HEV	Type	Variant
ER01	Ignition 15	X	X	Power Mini	ALL
ER02	CPSR		X	Power Mini	BD06
ER03	Front Defroster	X		Power Mini	DJ02
ER04	Engine System Relay	X	X	Power Mini	ALL
ER05	High Speed Cooling Fan Relay	X		Power Mini	EZ03
ER06	Horn	X	X	Micro	ALL
ER07	Low Current Relay (EV)			Mini	
ER08	Washer Pump Front	X	X	Micro (Spin)	ALL
ER09	Washer Pump Rear	X	X	Micro (Spin)	ALL
ER10	Head Lamp	X	X	Mini	ALL
ER11	Low Speed Cooling Fan	X		Mini	EZ03
ER12	Front Wiper Low Speed	X	X	Micro (Spin)	ALL
ER13	Front Wiper High Speed	X	X	Micro (Spin)	ALL
ER14	Head Pressure Washer Pump / Head Lamp			Micro	
ER15	Head Lamp (L3)			Mini	
ER16	Spare			Micro	
ER17	EOP			Micro	
ER18	Starter Relay	X		Mini	BD01
ER19	Spare			Micro	

The copying, distribution and utilization of this document as well as the communication of its contents to others without expressed authorization is prohibited. Offenders will be held liable for payment of damages. All rights reserved in the event of the grant of a patent, utility model or ornamental design registration.

GEELY

Document title		KX11_MP1_base_B7	
0B3_EJB_Armament_List			
Document Type	Release Status		
DRAW/ELSY	Released		
Document No		Edited	
8889755035		May/24/2021	
Issue		Page No	
007		3/83	

OB4 CJB Armament List

1. Fuse arrangement CJB

Fuse	Component	Logic	KX11 base	KX11 HEV	Type	Rate (A)	Variant
CF01	4/468 DRIVER DOOR MODULE DDM	KL30	X	X	Micro	30	ALL
CF02	4/469 PASSENGER DOOR MODULE PDM	KL30	X	X	Micro	30	ALL
CF03	4/154 CLIMATE CONTROL MODULE CCM	KL30	X	X	Micro	10	ALL
CF04	Rear Lamp Unit MCU Constant Power	KL30	X		Micro	5	DE05
CF05	4/222 CENTER CONSOLE SWITCH MODULE CCSM	KL30	X	X	Micro	7.5	ALL
	4/284 CENTER STACK DISPLAY CSD						
	4/905 PASSENGER SIDE DISPLAY PSD						
CF06	4/223 DRIVER INFORMATION MODULE DIM	KL30	X	X	Micro	5	ALL
	4/487 DRIVER INFORMATION SCREEN DIS						
CF07	Spare	KL30			Micro		
CF08	3/254 STEERING WHEEL MODULE AND STEERING ANGLE SENSOR SWM/SAS	KL30	X	X	Micro	5	ALL
	4/690 BLE AND NFC KEY COMMUNICATION MODULE BNCM						
CF09	4/489 DIGITAL VIDEO RECORDER DVR	KL30	X		Micro	5	G6A5
CF10	4/197 ELECTRONIC GEAR SELECTOR MODULE EGSM	KL30	X	X	Micro	5	ALL
	4/283 DRIVE MODE SWITCH MODULE DMSM						
	4/222 CENTER CONSOLE SWITCH MODULE CCSM (Start Switch)						
CF11	4/313 TELEMATICS AND CONNECTIVITY ANTENNA MODULE TCAM (NH03)	KL30	X	X	Micro	5	ALL
	4/117 TELEMATICS MODULE TEM (NH04)						
	4/162 RAIN AND LIGHT SENSOR MODULE RLSM						
	4/348 RADIO FREQUENCY ANTENNA RFA						
	4/902 EMERGENCY RESCUE ASSISTANT MODULE ERAM						
CF12	4/314 VEHICLE GATEWAY MODULE VGM	KL30	X	X	Micro	5	ALL
CF13	4/185 INFOTAINMENT HEAD UNIT IHU	KL30	X	X	Micro	15	ALL
CF14	4/189 HVAC BLOWER MODULE FRONT HBMF	KL30	X	X	Mcase	40	ALL
CF15	2/2/4 PASSENGER SEAT CONNECTION	KL30	X	X	Mcase	30	RV04 HC03
CF16	2/2/3 DRIVER SEAT CONNECTION	KL30	X	X	Mcase	30	RU04
CF17	3/254 STEERING WHEEL MODULE AND STEERING ANGLE SENSOR SWM/SAS	CR01	X		Micro	15	LK02
CF18	4/433 AIR FRAGRANCE UNIT AFU	CR01	X		Micro	5	H1A2
CF19	Spare	CR01			Micro		
CF20	Spare	CR01			Micro		
CF21	Spare	CR01			Micro		
CF22	Spare	CR01			Micro		
CF23	Spare	CR01			Micro		
CF24	Spare	CR01			Micro		
CF25	Spare	CR01			Mcase		
CF26	1/7/13 DIAGNOSTIC SOCKET OBD II	KL30	X	X	Micro	10	ALL
CF27	4/496 PARKING ASSIST SYSTEM PAS (PAS3)	KL30	X	X	Micro	5	LV03 & (LH01 LH04)
CF27	4/496 PARKING ASSIST SYSTEM PAS (PAS4)	KL30	X		Micro	10	LH07
CF28	Relay Coil	KL30	X	X	Micro	5	ALL
CF29	4/565 ELECTRONIC TOLL COLLECT MODULE ETCM	KL30	X	X	Micro	5	AS02 & MA10
	4/489 DIGITAL VIDEO RECORDER DVR						
CF30	Spare	KL30			Micro		
CF31	Spare	KL30			Micro		
CF32	4/245 SIDE OBSTACLE DETECTION LEFT SODL	KL30	X		Micro	5	C802
	4/246 SIDE OBSTACLE DETECTION RIGHT SODR						
CF33	4/539 REAR LEFT DOOR MODULE RLDM	KL30	X	X	Micro	25	ALL
CF34	Spare	KL30			Micro		
CF35	4/184 ACTIVE SAFETY DOMAIN MASTER ASDM	KL30	X	X	Micro	5	L303 L304 L03
CF36	4/540 REAR RIGHT DOOR MODULE RRDM	KL30	X	X	Micro	25	ALL
CF37	Spare	KL30			Micro		
CF38	Spare	KL30			Micro		
CF39	4/218 AUDIO MODULE AUD	KL30	X		Mcase	20	NG03 NF03
CF40	Spare	KL30			Mcase		
CF41	4/211 RESTRAINT MODULE LEFT RML	KL30	X		Mcase	40	HRA3
CF42	Spare	KL30			Mcase		
CF43	4/116 POWER OPERATED TAILGATE POT	KL30	X	X	Mcase	30	LE02
CF44	4/428 SEAT MODULE BACK SMB	KL30	X		Mcase	30	HD04
CF45	Spare	KL30			Mcase		
CF46	4/56 CENTRAL ELECTRONIC MODULE CEM	KL30	X	X	Mcase	40	ALL
CF47	Spare	KL30			Mcase		
CF48	4/44 COIL POWER STAGE	KL30	X	X	Mcase	30	ALL
CF49	4/56 CENTRAL ELECTRONIC MODULE CEM	KL30	X	X	Mcase	40	ALL
CF50	Spare	KL30			Micro		
CF51	16/120.3 ETC UNIT 3	KL30		X	Micro	10	BD06
	16/120.4 ETC UNIT 4						
CF52	4/176 SUPPLEMENTARY RESTRAINT SYSTEM SRS	KL30	X	X	Micro	5	ALL
CF53	Spare	KL30			Micro		
CF54	4/83 PUMP ELECTRONIC MODULE PEM	KL30	X	X	Micro	20	ALL
CF55	Spare	KL30			Micro		
CF56	6/32 REAR WIPER MOTOR	KL30	X	X	Micro	15	ALL
CF57	Spare	CR05			Micro		
CF58	Spare	CR05			Micro		
CF59	4/82 DIFFERENTIAL ELECTRONIC MODULE DEM	CR05	X		Micro	15	CC02
CF60	Spare	CR05			Micro		
CF61	Spare	CR05			Micro		
CF62	Spare	CR05			Micro		
CF63	1/7/44 POWER OUTLET PASSENGER COMPARTMENT	CR06	X	X	Micro	15	ALL
CF64	1/7/19 POWER OUTLET LUGGAGE COMP	CR06	X	X	Micro	15	NP02
CF65	1/7/60 USB CHARGING PORT TUNNEL REAR	CR06	X	X	Micro	10	E702 E706
CF66	Spare	CR06			Micro		
CF67	Spare	CR06			Micro		
CF68	1/7/42 USB CONNECTION	CR07	X	X	Micro	10	ALL
	4/312 WIRELESS PHONE CHARGER WPC						
CF69	IP Components	CR07	X	X	Micro	7.5	ALL
CF70	4/170 REAR CONSOLE SWITCH MODULE RCSM	CR07	X		Micro	5	EC04
CF71	4/33 SUNROOF CONTROL MODULE SRM	CR07	X	X	Micro	20	AL04
CF72	4/228 HEAD UP DISPLAY HUD	CR07	X		Micro	5	NS03
CF73	4/290 FORWARD LOOKING CAMERA FLC	CR07	X	X	Micro	5	SH02
CF74	Spare	CR07			Micro		
CF75	Spare	CR07			Micro		
CF76	Spare	CR07			Micro		
CF77	Spare	CR07			Micro		
CF78	Spare	CR07			Micro		
CF79	Spare	CR07			Micro		
CF80	Spare	CR07			Micro		
CF114	Spare	KL30			Mcase		
CF115	Spare	KL30			Mcase		
CF116	Spare	KL30			Micro		
CF117	Spare	KL30			Micro		
CF118	Spare	KL30			Micro		
CF119	Spare	KL30			Micro		
M1	Spare	KL30			Midi		

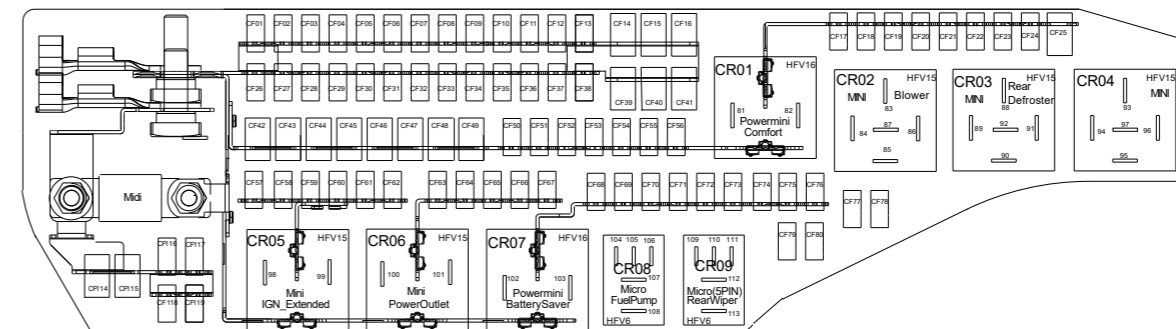

2. Relay arrangement CJB

Relay	Component	KX11 base	KX11 HEV	Type	Variant
CR01	Comfort Relay	X		Power Mini	LK02 H1A2
CR02	Blower Relay	X	X	Mini	ALL
CR03	Rear Defroster Relay	X	X	Mini	ALL
CR04	Spare			Mini	
CR05	IG Extended Relay	X		Mini	CC02
CR06	Power Outlet Relay	X	X	Mini	ALL
CR07	Battery Saver Relay	X	X	Power Mini	ALL
CR08	Fuel Pump Relay	X	X	Micro	ALL
CR09	Rear Wiper Relay	X	X	Micro (5pin)	ALL

3. Fuse & Relay Part number

Micro Fuses		
Fuse Rate (A)	Color	VCC PN
5	Tan	31346545
7.5	Brown	31346546
10	Red	31346547
15	Blue	31346548
20	Yellow	31346549
25	White	31346550
30	Green	31346551

Mcase Fuses		
Fuse Rate (A)	Color	VCC PN
20	Blue	31346532
30	Pink	31346534
40	Green	31346535

Relays	
Type	SPN
Micro	HFV6/012HS-TR
Micro (5pin)	HFV6/012Z-TR(8553)
Mini	HFV15/12-H11J-R(8625)
Power Mini	HFV16/12-H11Y-R(8626)

The copying, distribution and utilization of this document as well as the communication of its contents to others without expressed authorization is prohibited. Offenders will be held liable for payment of damages. All rights reserved in the event of the grant of a patent, utility model or ornamental design registration.

GEELY

Document title KX11_MP1_base_B7	
OB4_CJB_Armament_List	
Document Type DRAW/ELSY	Release Status Released
Document No 8889755035	Edited September/22/2021
Issue 007	Page No 4/83

1A1 Electrical Distribution EJB

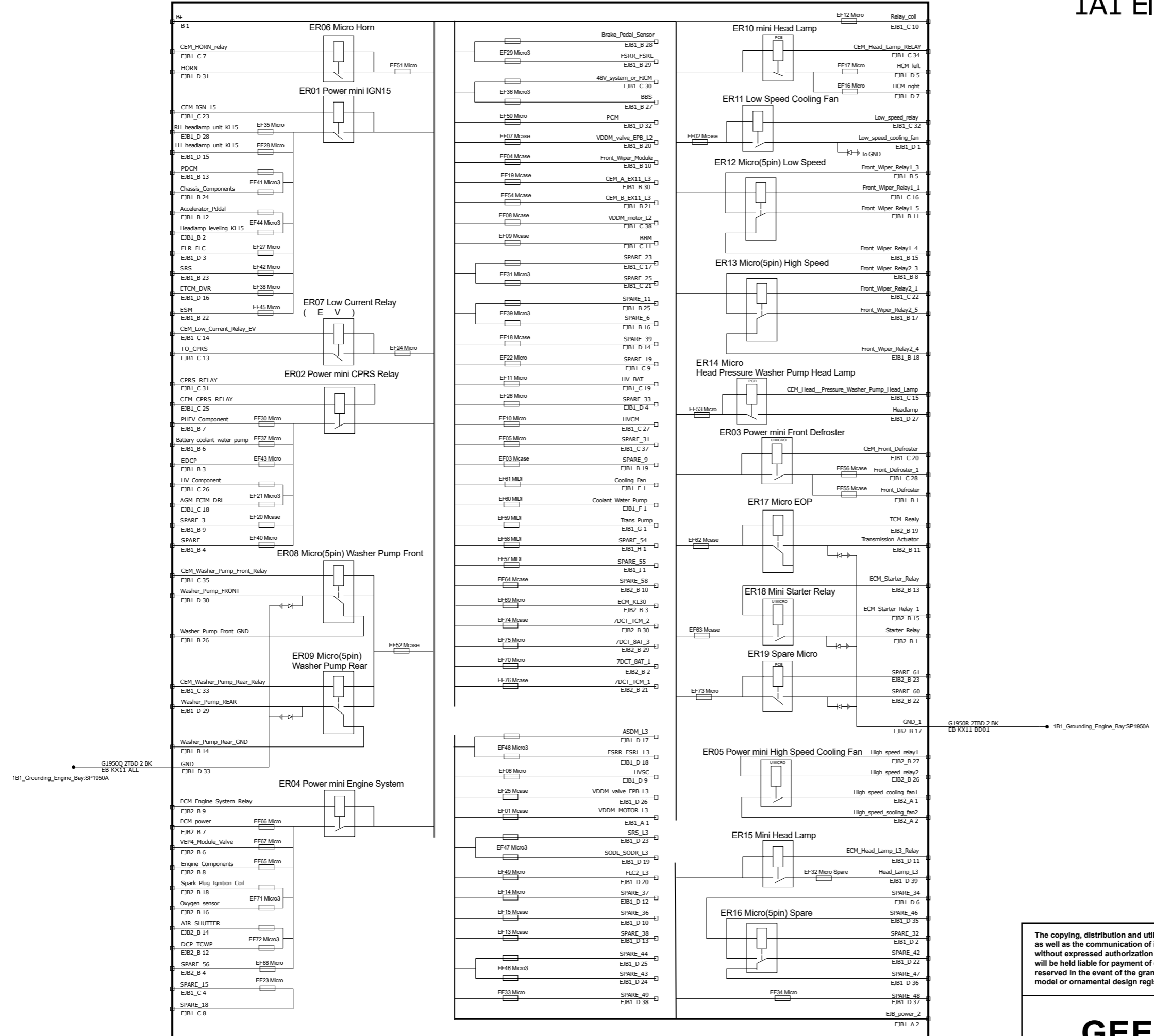

<p>The copying, distribution and utilization of this document as well as the communication of its contents to others without expressed authorization is prohibited. Offenders will be held liable for payment of damages. All rights reserved in the event of the grant of a patent, utility model or ornamental design registration.</p>		<p>Document title KX11_MP1_base_B7</p>	
		<p>1A1_Electrical_Distribution_EJB</p>	
<p>Document Type DRAW/ELSY</p>		<p>Release Status Released</p>	
<p>Document No 8889755035</p>		<p>Edited January/19/2021</p>	
<p>Issue 007</p>		<p>Page No 5/83</p>	

GEELY

1A2 Electrical Distribution CJB

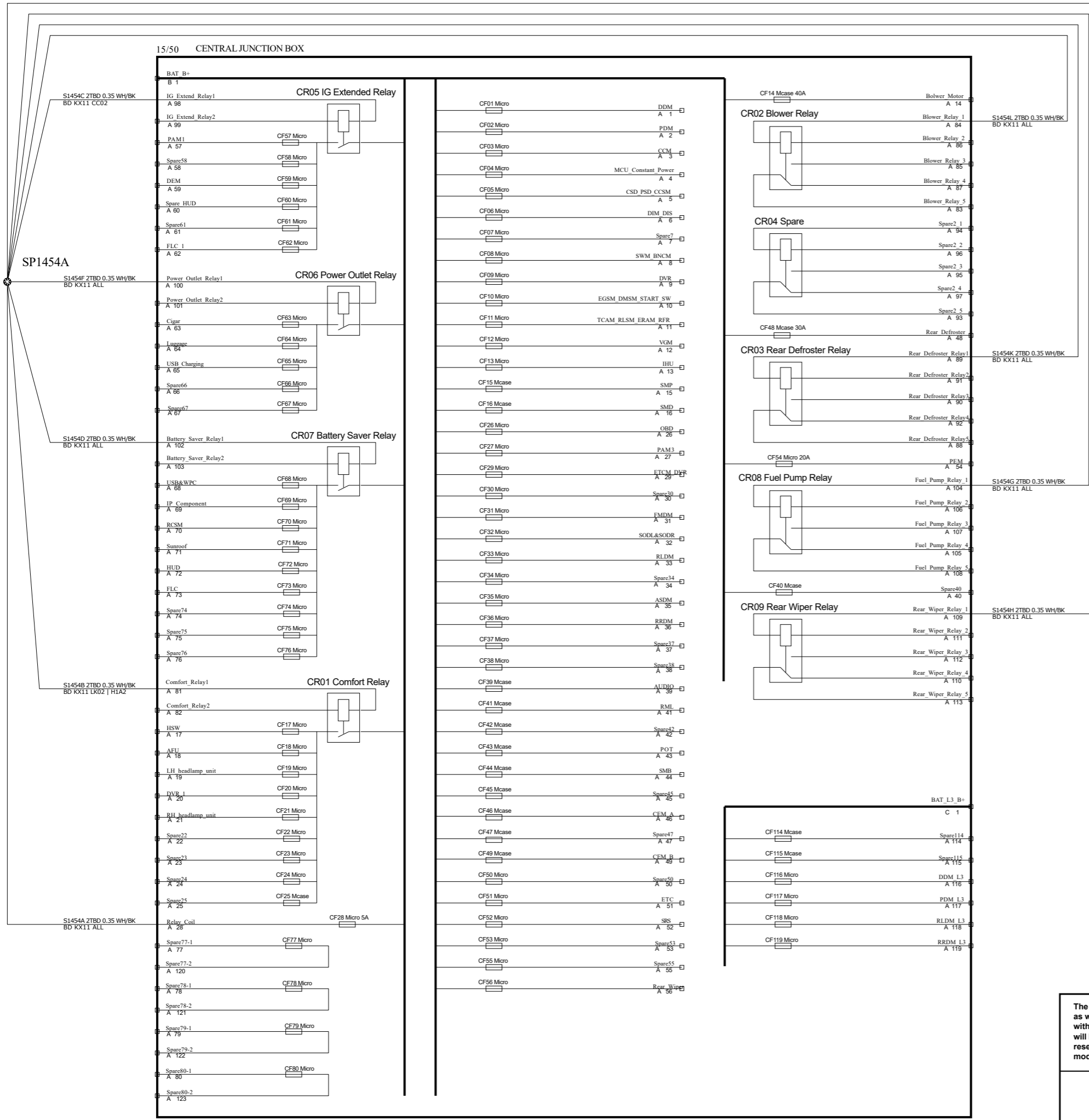

<p>The copying, distribution and utilization of this document as well as the communication of its contents to others without expressed authorization is prohibited. Offenders will be held liable for payment of damages. All rights reserved in the event of the grant of a patent, utility model or ornamental design registration.</p>		Document title KX11_MP1_base_B7 1A2_Electrical_Distribution_CJB	
		Document Type DRAW/ELSY	Release Status Released
<h1 style="text-align: center;">GEELY</h1>		Document No 8889755035	Edited September/22/2021
		Issue 007	Page No 6/83

1A4 Electrical Distribution Relays Control

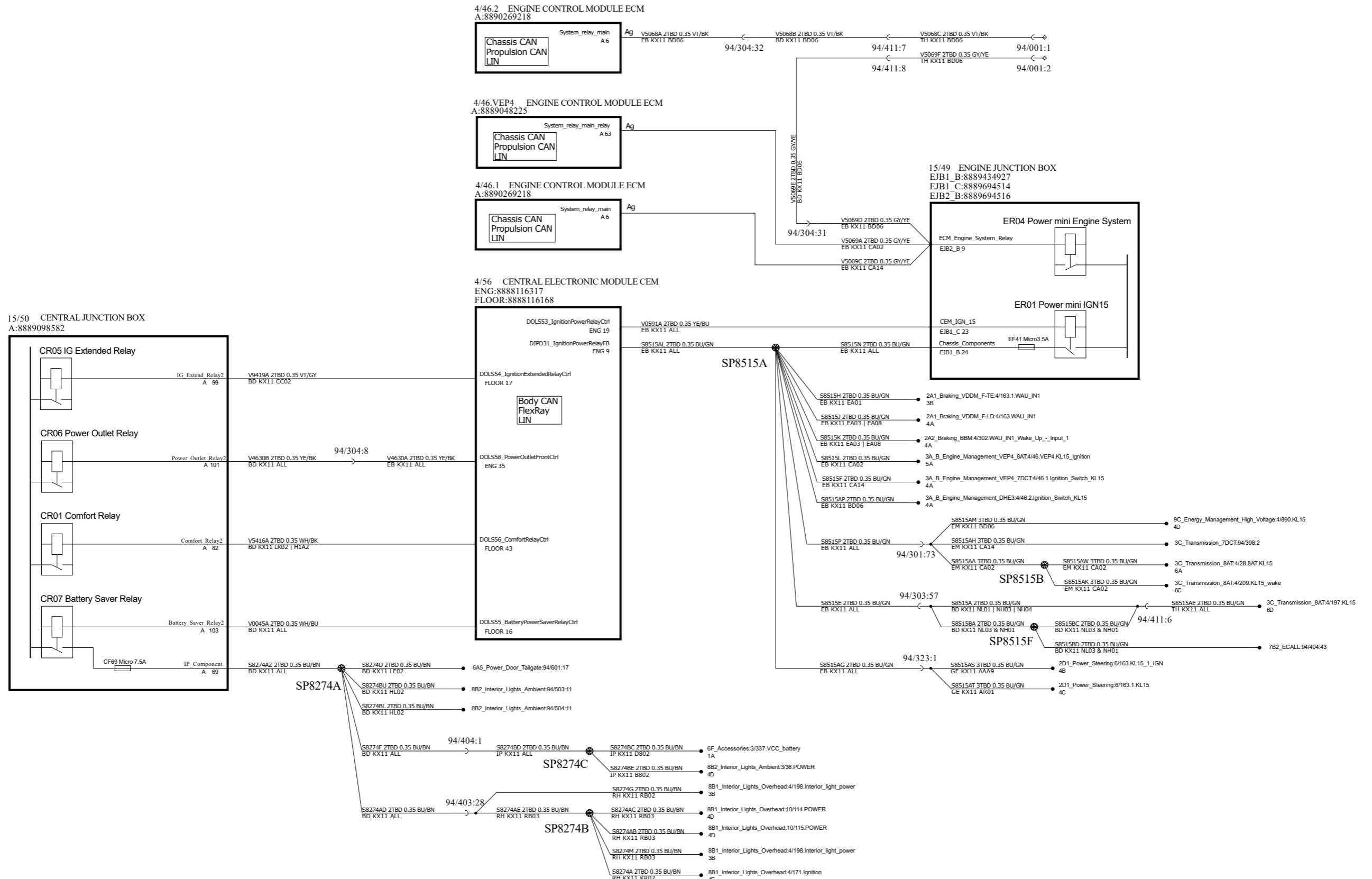

GEELY

1B1 Grounding Engine Bay

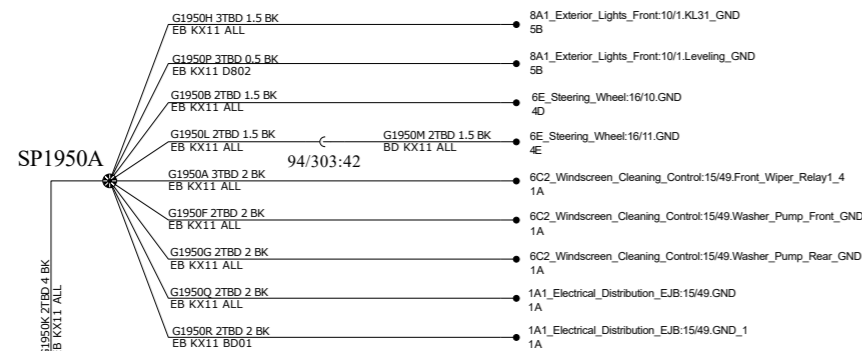

31/2 GROUND LEFT FRONT WHEEL ARCH 1
A:E29115500



31/5.1 GROUND WIPER
K031667L-6-2

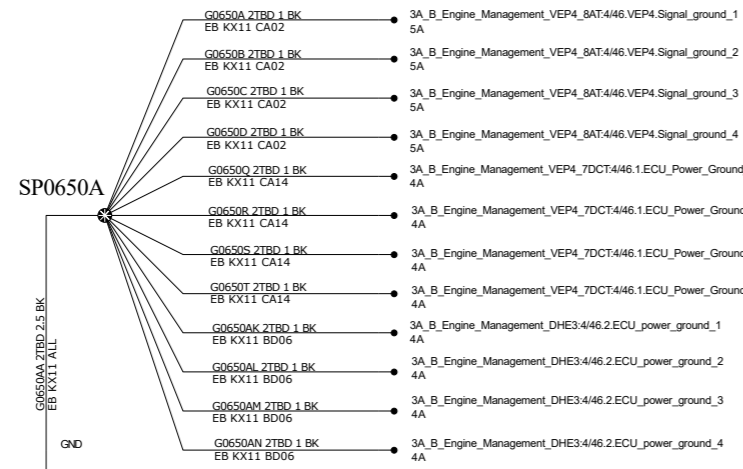

31/19 GROUND ECM
K031668L-6-5

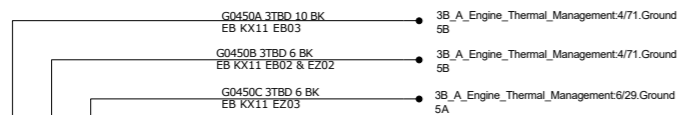

31/8 COOLING FAN 2 GND
E29652800



31/23 GROUND BBM
E18028800

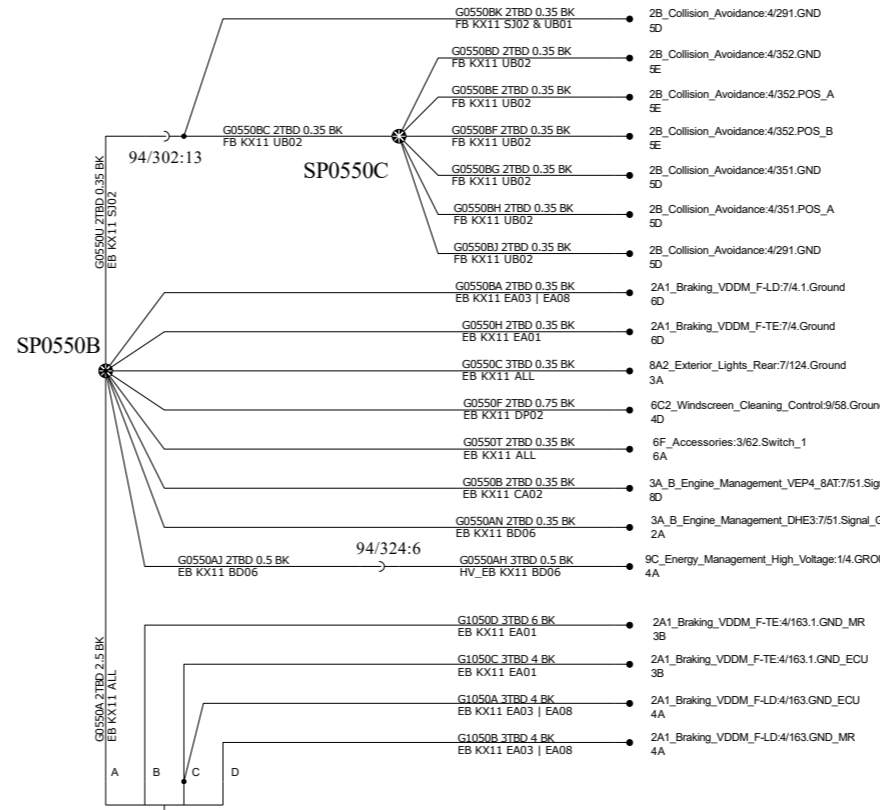

31/3 GROUND LEFT REAR ENGINE BAY 1
A:E29083100
B:E29083300
C:E29083200
D:E29083200

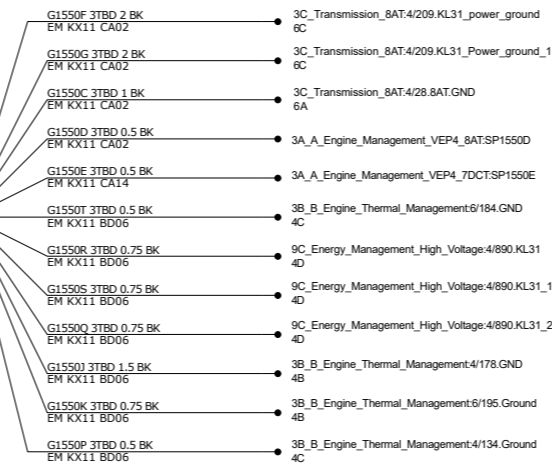

31/10 ECM/TCM GROUND
A:E29083100
B:8888120083

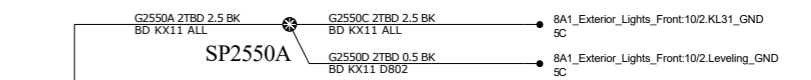
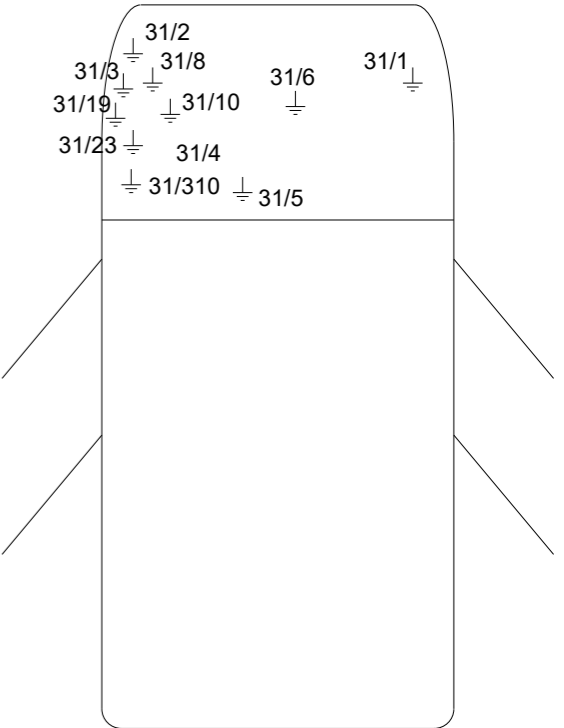
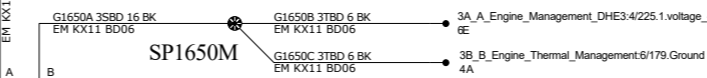

31/1 GROUND RIGHT FRONT WHEEL ARCH 1
B:E29115500

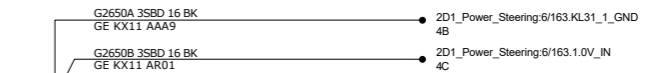

31/310 EPAS GND
A:E27876500

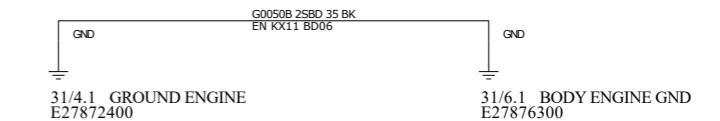
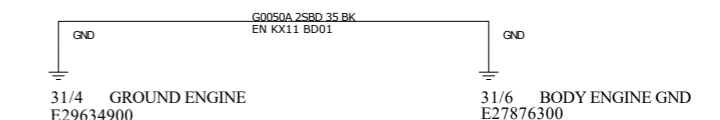

<p>The copying, distribution and utilization of this document as well as the communication of its contents to others without expressed authorization is prohibited. Offenders will be held liable for payment of damages. All rights reserved in the event of the grant of a patent, utility model or ornamental design registration.</p> <h1 style="text-align: center;">GEELY</h1>		<p>Document title KX11_MP1_base_B7</p> <p>1B1_Grounding_Engine_Bay</p>	
		<p>Document Type DRAW/ELSY</p>	<p>Release Status Released</p>
		<p>Document No 8889755035</p> <p>Issue 007</p>	<p>Edited May/08/2021</p> <p>Page No 8/83</p>

1B2 Grounding IP Roof

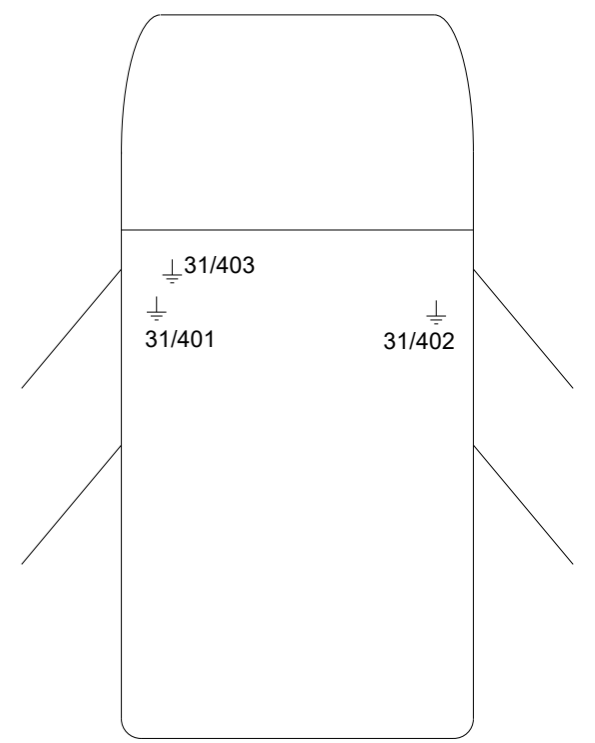
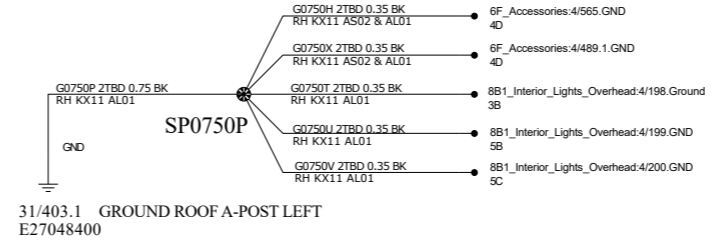
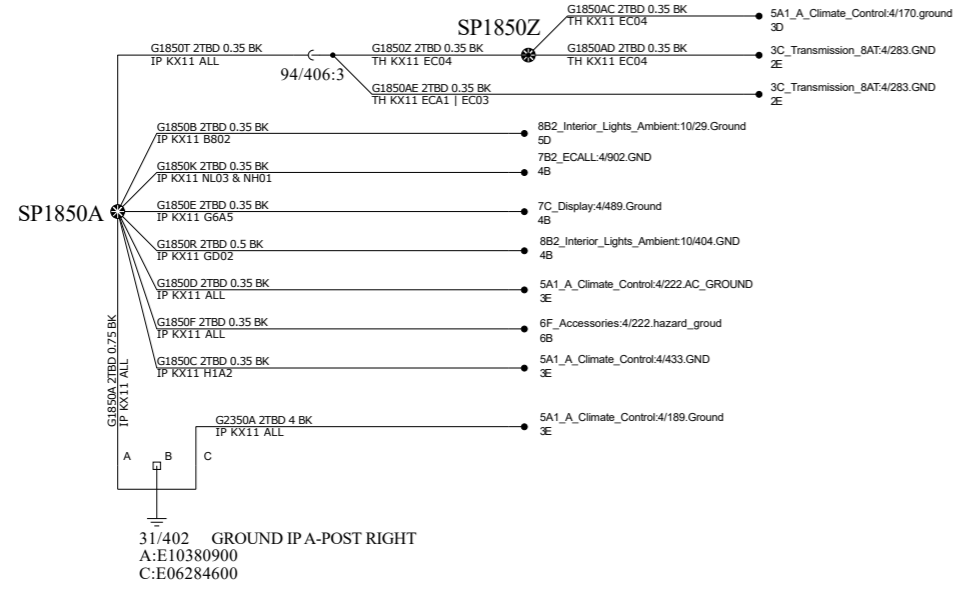
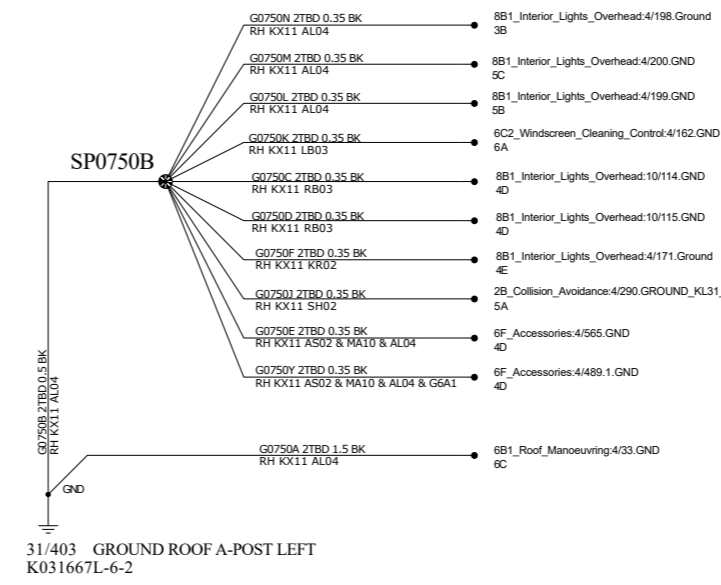
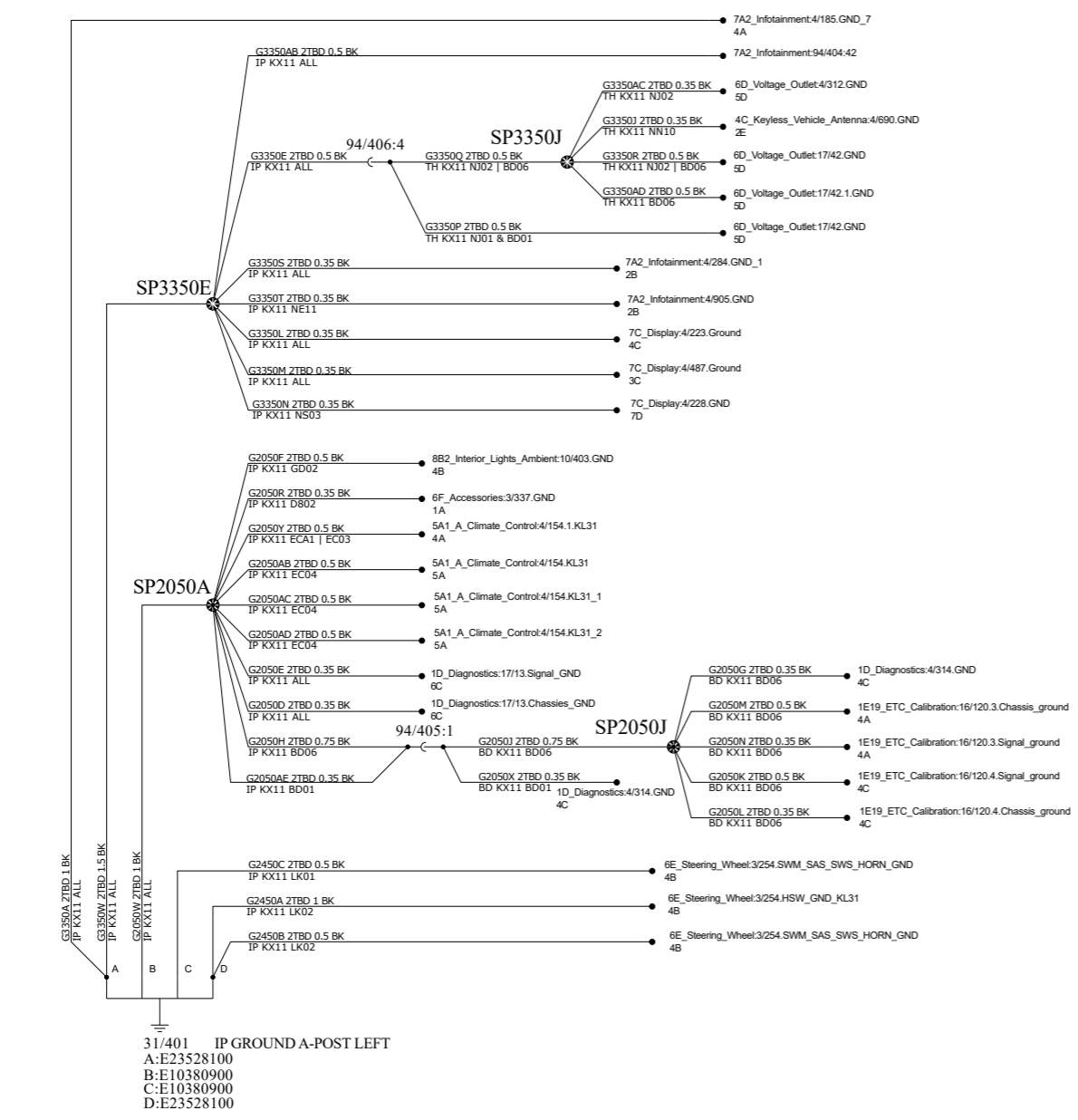

GEELY	Document title KX11_MP1_base_B7 1B2_Grounding_IP_Roof	
	Document Type DRAW/ELSY	Release Status Released
	Document No 8889755035	Edited September/22/2021
	Issue 007	Page No 9/83

1B3 Grounding Body Front

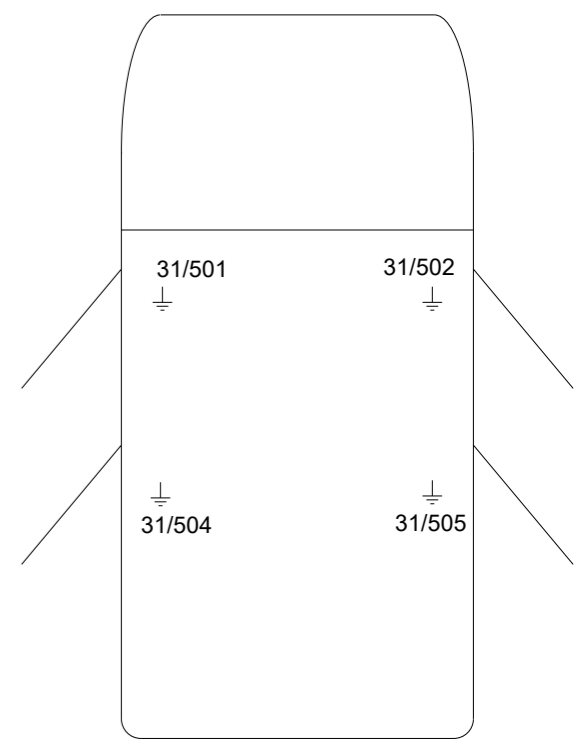
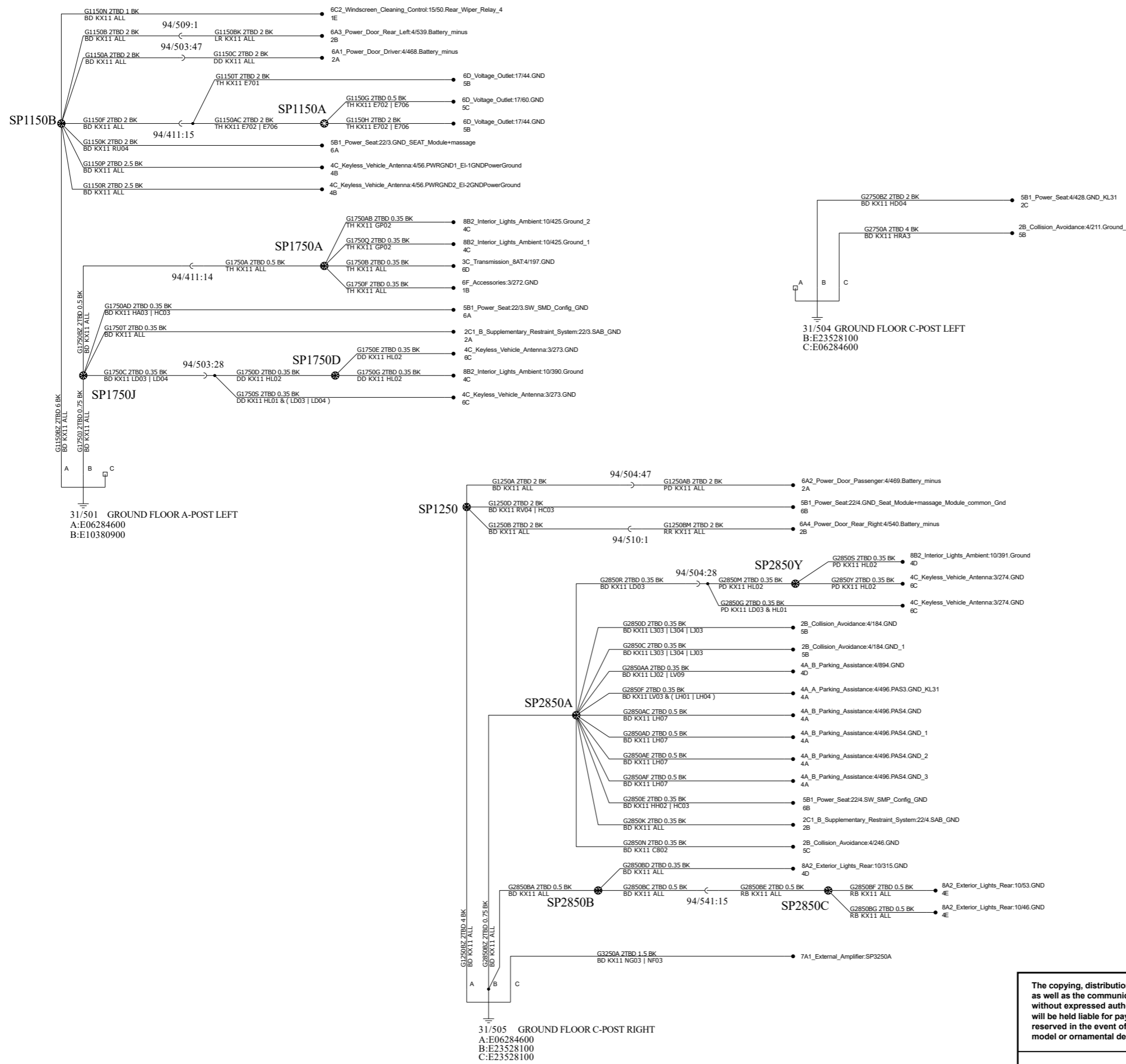

<p>The copying, distribution and utilization of this document as well as the communication of its contents to others without expressed authorization is prohibited. Offenders will be held liable for payment of damages. All rights reserved in the event of the grant of a patent, utility model or ornamental design registration.</p>		Document title KX11_MP1_base_B7 1B3_Grounding_Body_Front	
		Document Type DRAW/ELSY	Release Status Released
		Document No 8889755035	Edited June/17/2021
		Issue 007	Page No 10/83

1B4 Grounding Body Rear Tailgate

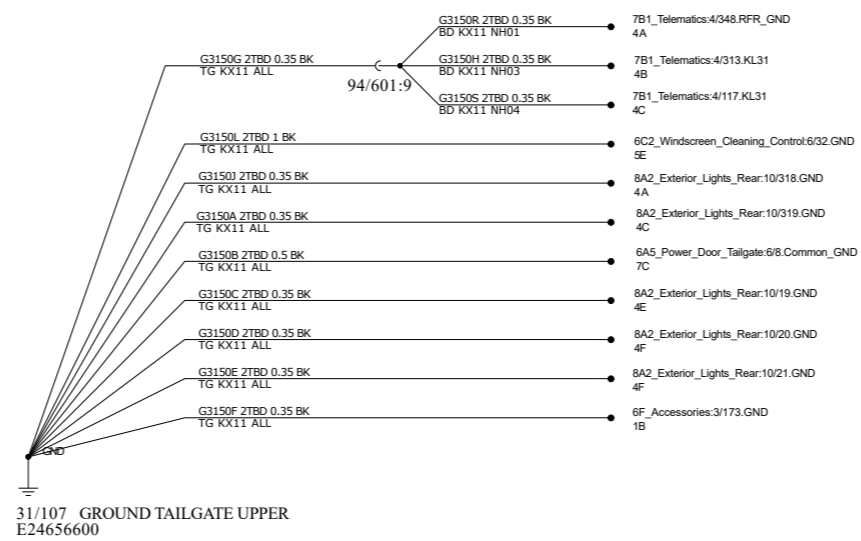
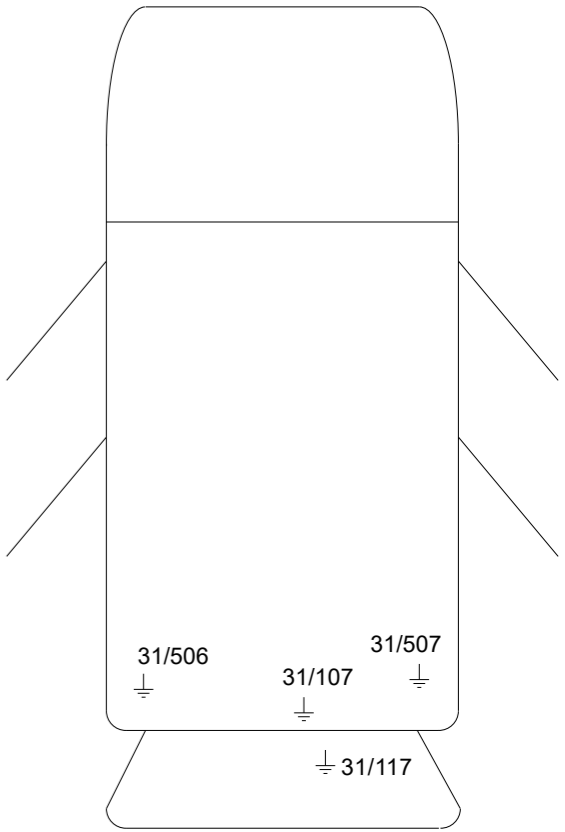
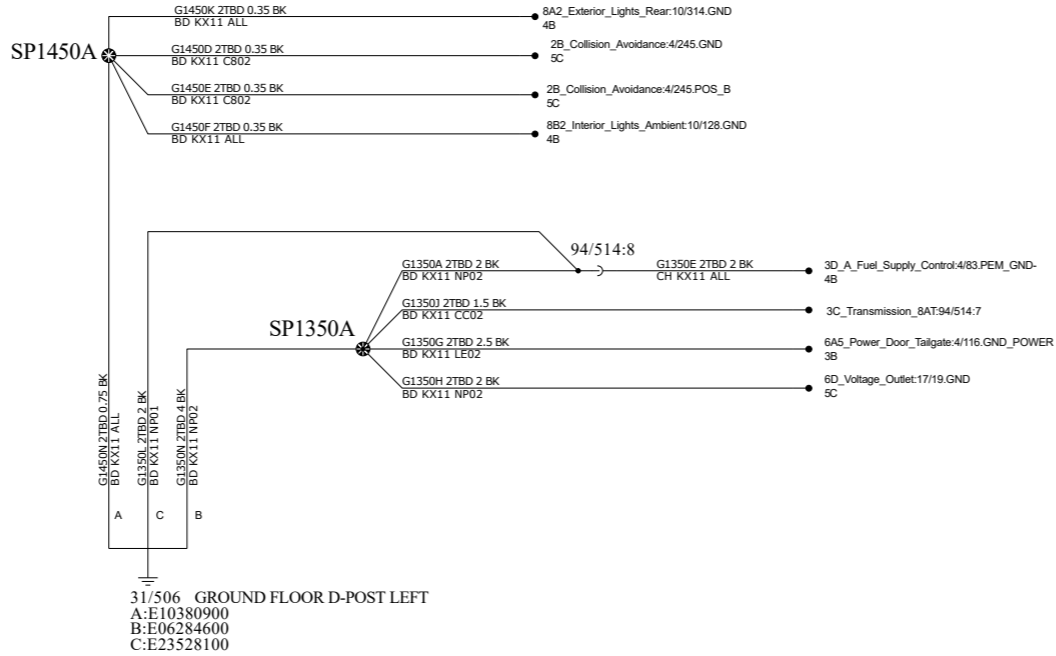

<p>The copying, distribution and utilization of this document as well as the communication of its contents to others without expressed authorization is prohibited. Offenders will be held liable for payment of damages. All rights reserved in the event of the grant of a patent, utility model or ornamental design registration.</p> <p style="text-align: center; font-size: 24pt; font-weight: bold;">GEELY</p>	<p>Document title KX11_MP1_base_B7 1B4_Grounding_Body_Rear_Tailgate</p>	
	<p>Document Type DRAW/ELSY</p>	<p>Release Status Released</p>
	<p>Document No 8889755035</p>	<p>Edited April/23/2021</p>
	<p>Issue 007</p>	<p>Page No 11/83</p>

1C Power Generating

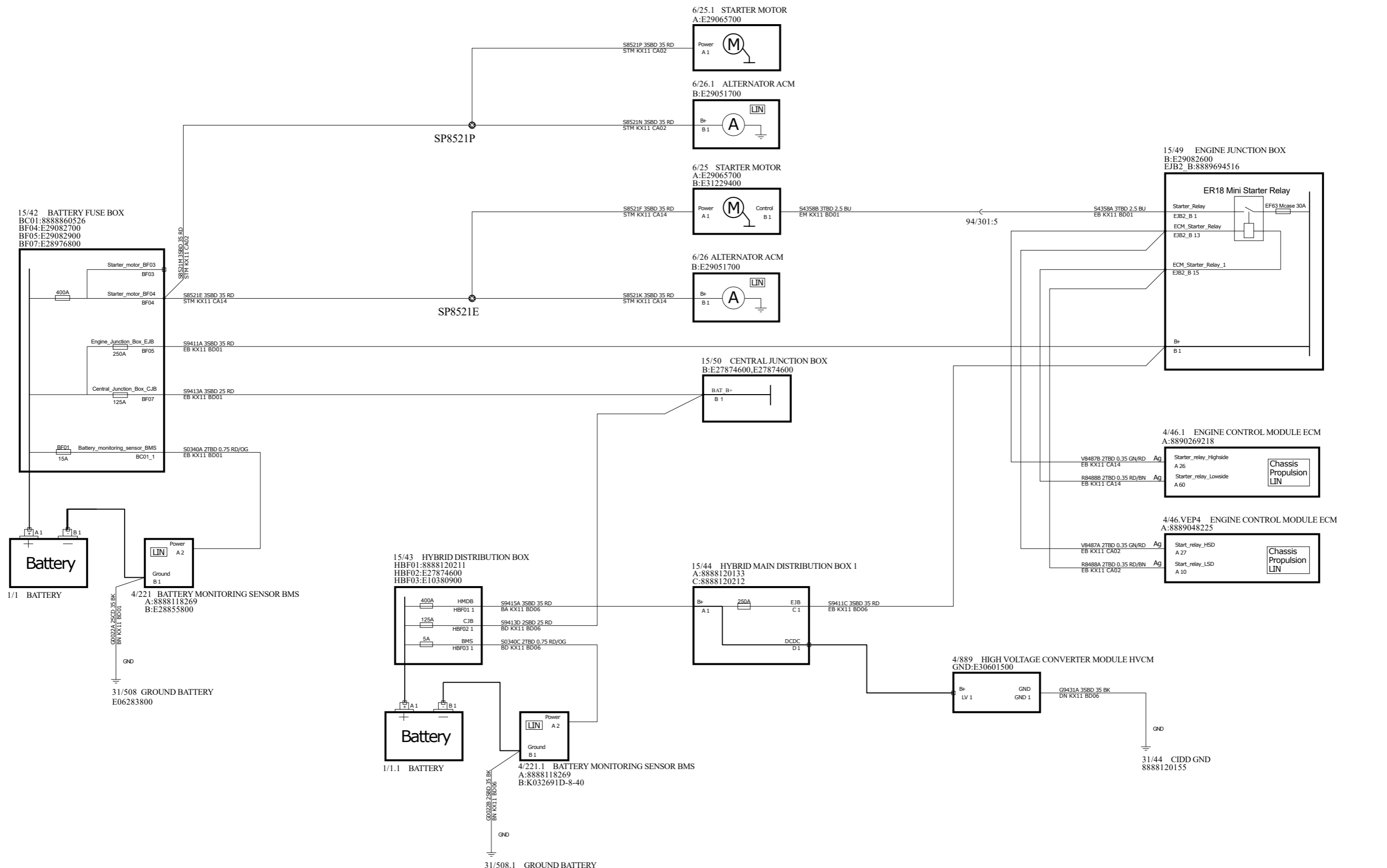

<p>The copying, distribution and utilization of this document as well as the communication of its contents to others without expressed authorization is prohibited. Offenders will be held liable for payment of damages. All rights reserved in the event of the grant of a patent, utility model or ornamental design registration.</p> <h1 style="margin: 0;">GEELY</h1>	Document title KX11_MP1_base_B7 1C_Power_Generating	
	Document Type DRAW/ELSY	Release Status Released
	Document No 8889755035	Edited June/21/2021
	Issue 007	Page No 12/83

1D Diagnostics

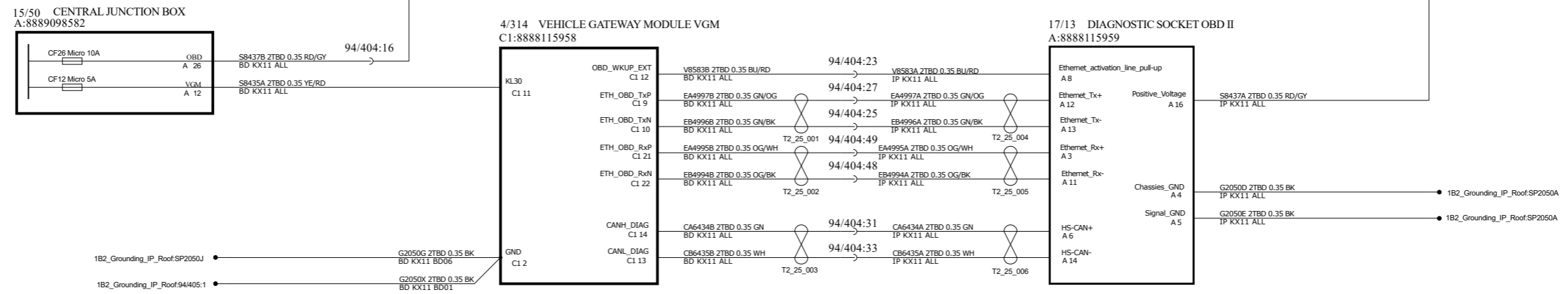

GEELY	Document title KX11_MP1_base_B7	
	1D_Diagnostics	
	Document Type DRAW/ELSY	Release Status Released
	Document No 8889755035	Edited April/16/2021
	Issue 007	Page No 13/83

Backbone FlexRay

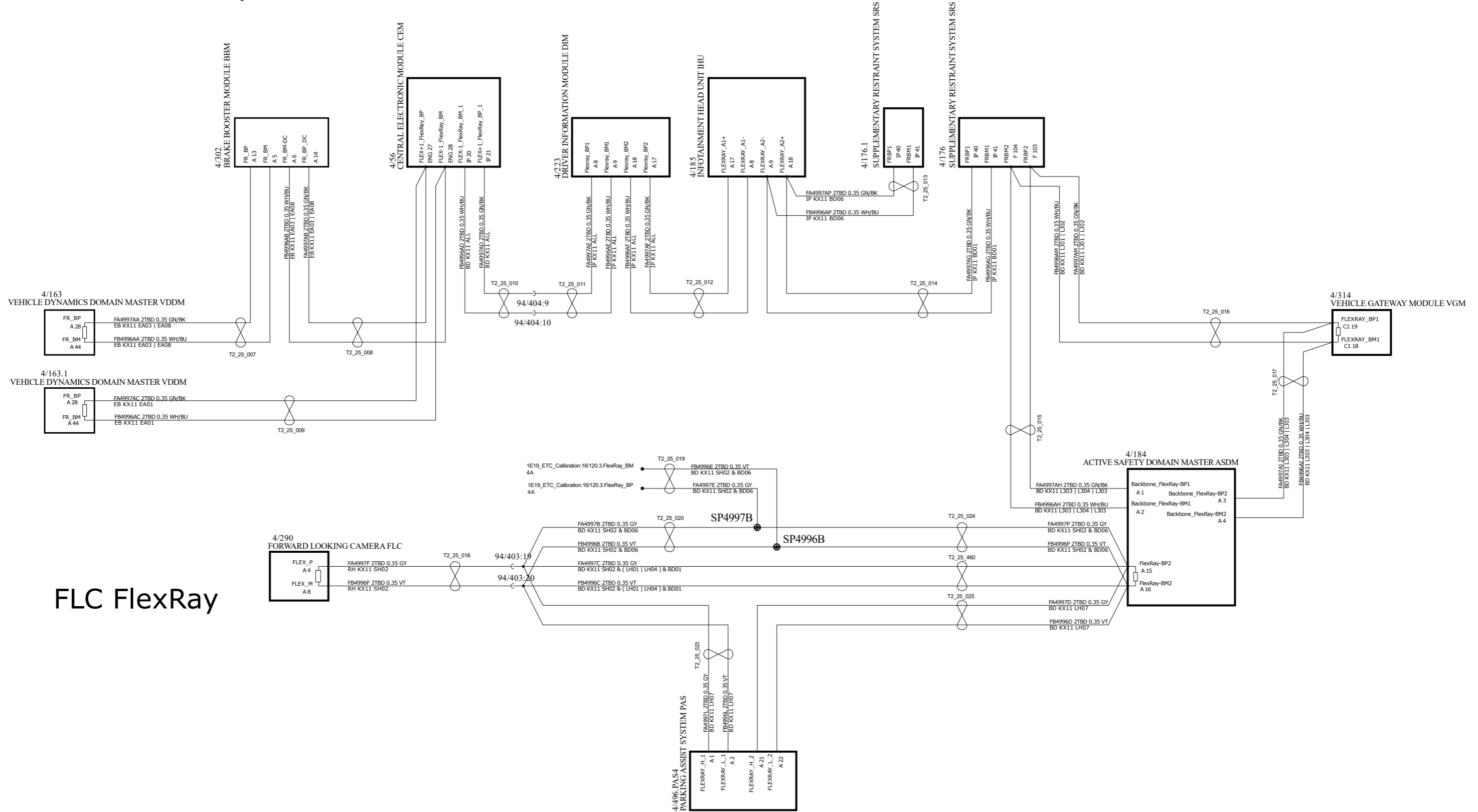

<p>The copying, distribution and utilization of this document as well as the communication of its contents to others without expressed authorization is prohibited. Offenders will be held liable for payment of damages. All rights reserved in the event of the grant of a patent, utility model or ornamental design registration.</p> <p style="text-align: center;">GEELY</p>	Document title KX11_MP1_base_B7 1E1_Flexray_Backbone	
	Document Type DRAW/ELSY	Release Status Released
	Document No 8889755035	Edited April/16/2021
	Issue 007	Page No 14/83

1E2 Body CAN

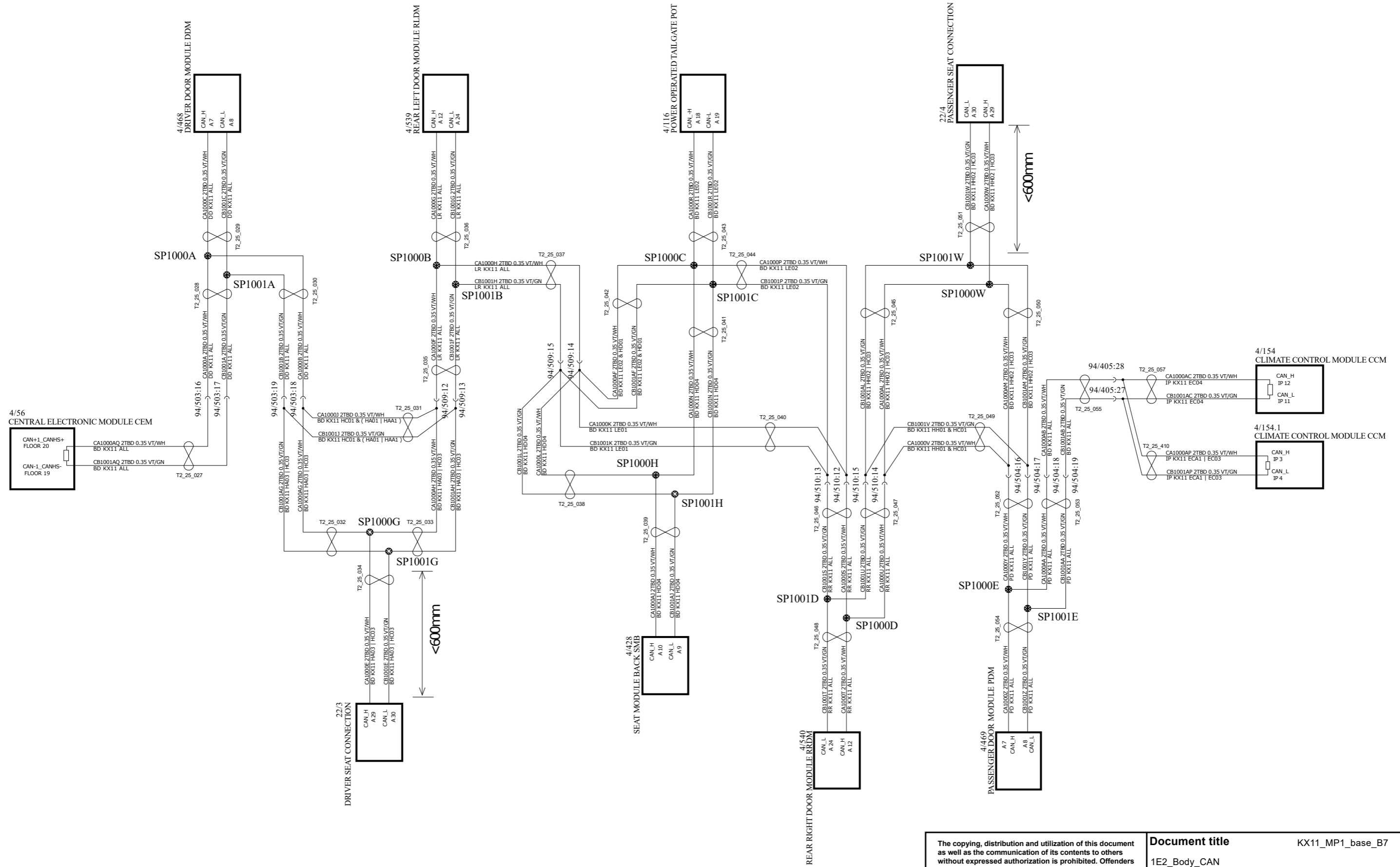

The copying, distribution and utilization of this document as well as the communication of its contents to others without expressed authorization is prohibited. Offenders will be held liable for payment of damages. All rights reserved in the event of the grant of a patent, utility model or ornamental design registration.

GEELY

Document title		KX11_MP1_base_B7	
1E2_Body_CAN			
Document Type	DRAW/ELSY	Release Status	Released
Document No	8889755035	Edited	December/15/2020
Issue	007	Page No	15/83

1E3 Body Exposed CAN

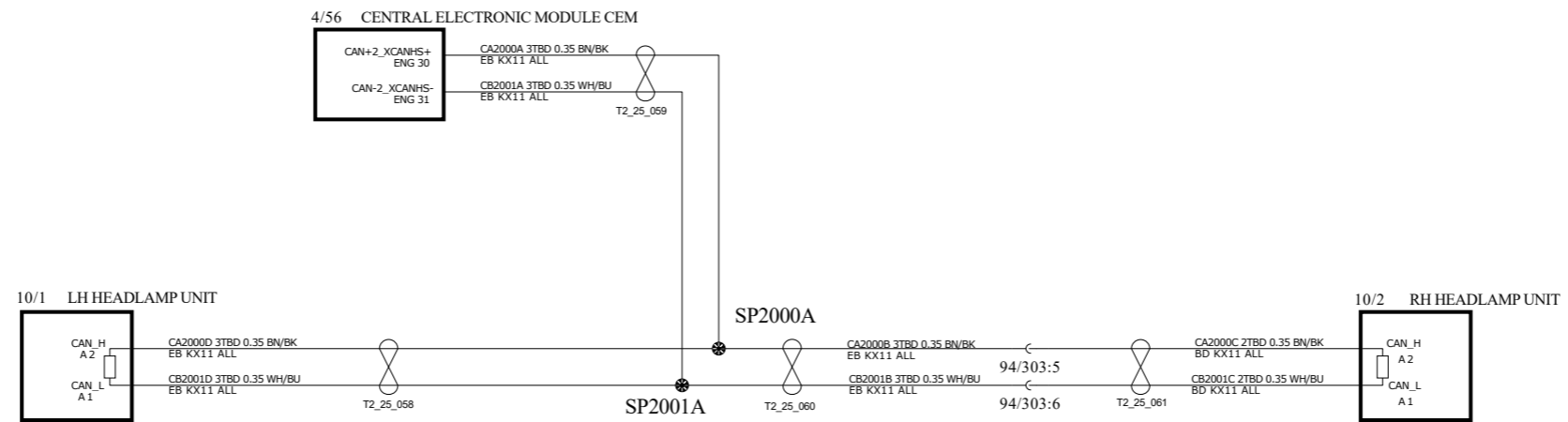

<p>The copying, distribution and utilization of this document as well as the communication of its contents to others without expressed authorization is prohibited. Offenders will be held liable for payment of damages. All rights reserved in the event of the grant of a patent, utility model or ornamental design registration.</p> <p style="text-align: center;">GEELY</p>	Document title KX11_MP1_base_B7 1E3_Body_Exposed_CAN	
	Document Type DRAW/ELSY	Release Status Released
	Document No 8889755035	Edited December/04/2020
	Issue 007	Page No 16/83

1E4 Chassis CAN1

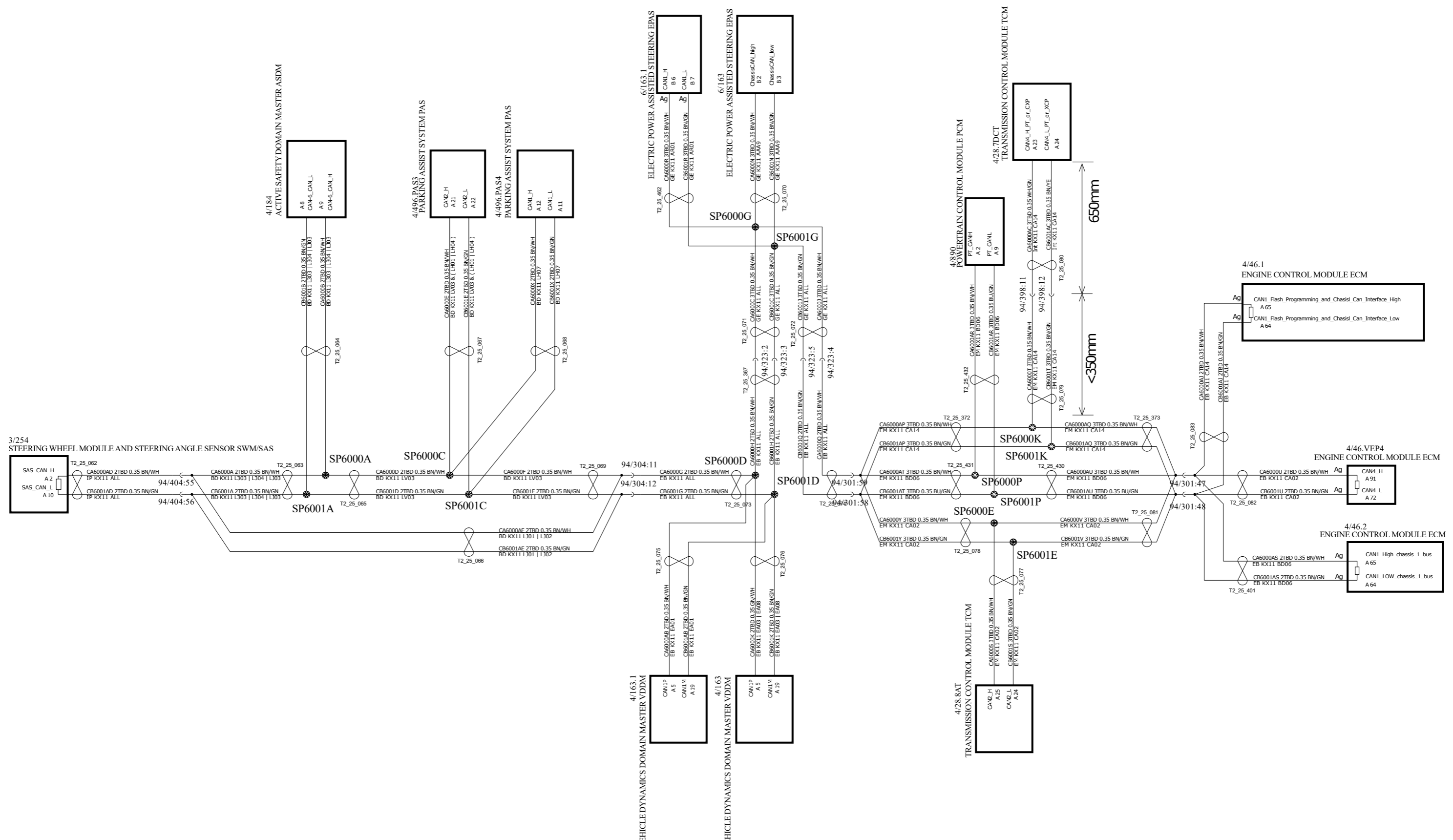

<p>The copying, distribution and utilization of this document as well as the communication of its contents to others without expressed authorization is prohibited. Offenders will be held liable for payment of damages. All rights reserved in the event of the grant of a patent, utility model or ornamental design registration.</p>		<p>Document title KX11_MP1_base_B7</p>	
		<p>1E4_Chassis_CAN1</p>	
<p>Document Type DRAW/ELSY</p>		<p>Release Status Released</p>	
<p>Document No 8889755035</p>		<p>Edited April/16/2021</p>	
<p>Issue 007</p>		<p>Page No 17/83</p>	

GEELY

1E5 Chassis CAN2

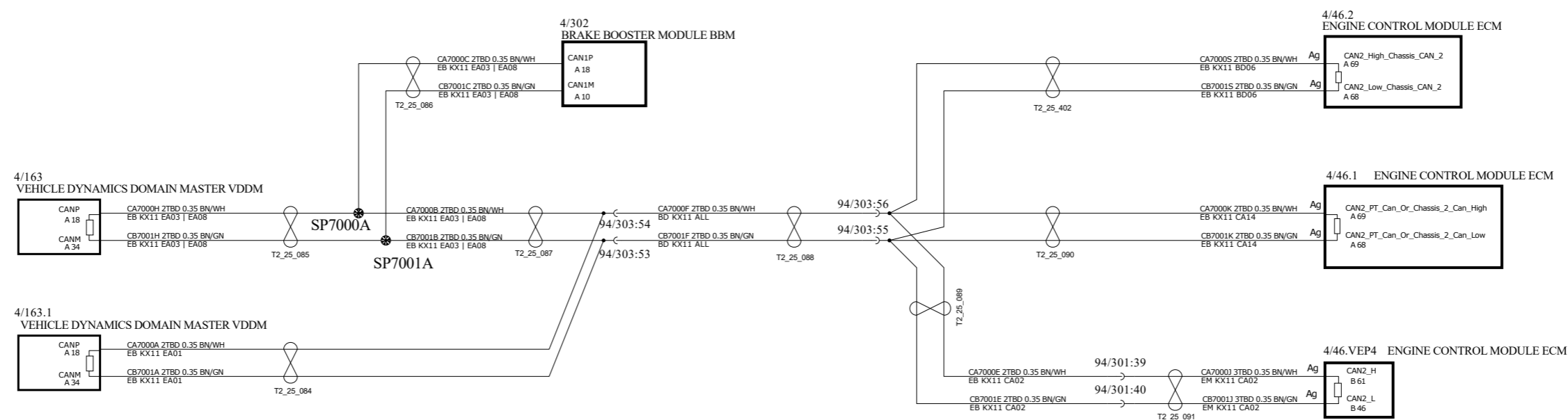

<p>The copying, distribution and utilization of this document as well as the communication of its contents to others without expressed authorization is prohibited. Offenders will be held liable for payment of damages. All rights reserved in the event of the grant of a patent, utility model or ornamental design registration.</p> <p style="text-align: center;">GEELY</p>	Document title KX11_MP1_base_B7 1E5_Chassis_CAN2	
	Document Type DRAW/ELSY	Release Status Released
	Document No 8889755035	Edited December/28/2020
	Issue 007	Page No 18/83

1E6 Passive Safety CAN

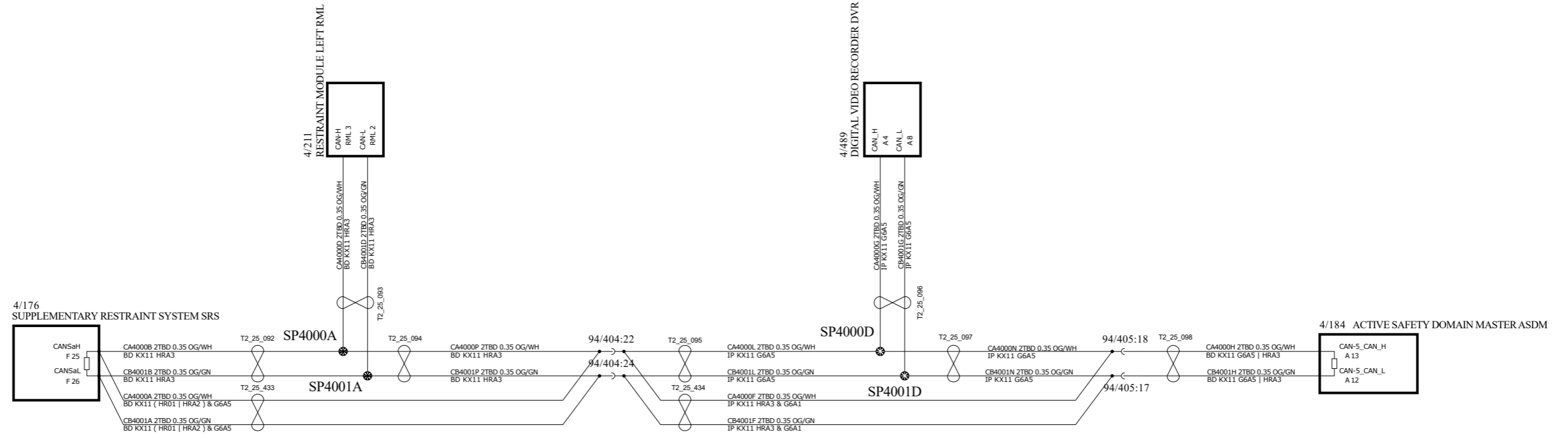

GEELY	Document title KX11_MP1_base_B7 1E6_Passive_Safety_CAN	
	Document Type DRAW/ELSY	Release Status Released
	Document No 8889755035	Edited April/16/2021
	Issue 007	Page No 19/83

1E7 Propulsion CAN

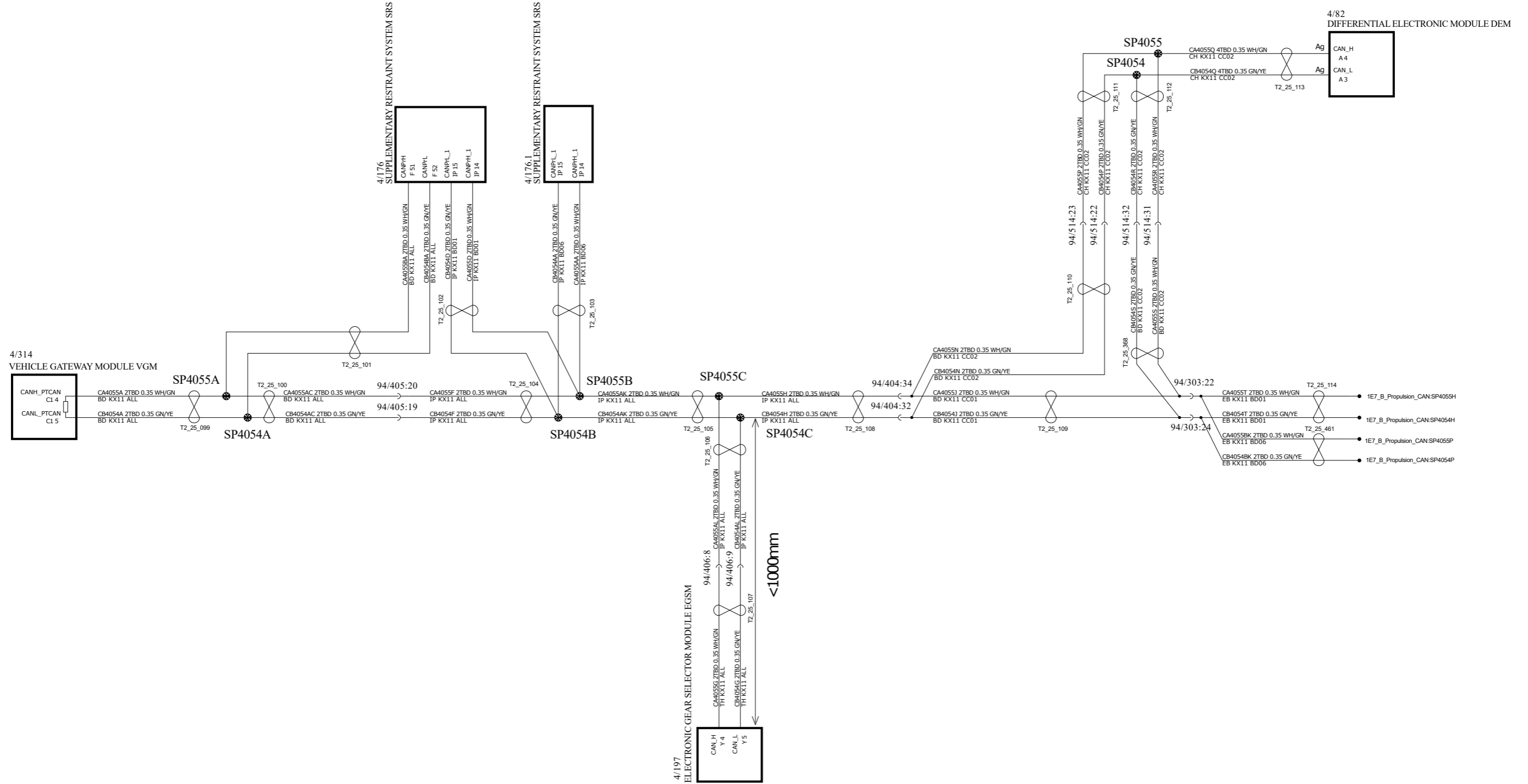

<p>The copying, distribution and utilization of this document as well as the communication of its contents to others without expressed authorization is prohibited. Offenders will be held liable for payment of damages. All rights reserved in the event of the grant of a patent, utility model or ornamental design registration.</p> <h2 style="margin: 0;">GEELY</h2>	Document title KX11_MP1_base_B7 1E7_A_Propulsion_CAN	
	Document Type DRAW/ELSY	Release Status Released
	Document No 8889755035	Edited April/16/2021
	Issue 007	Page No 20/83

1E7 Propulsion CAN

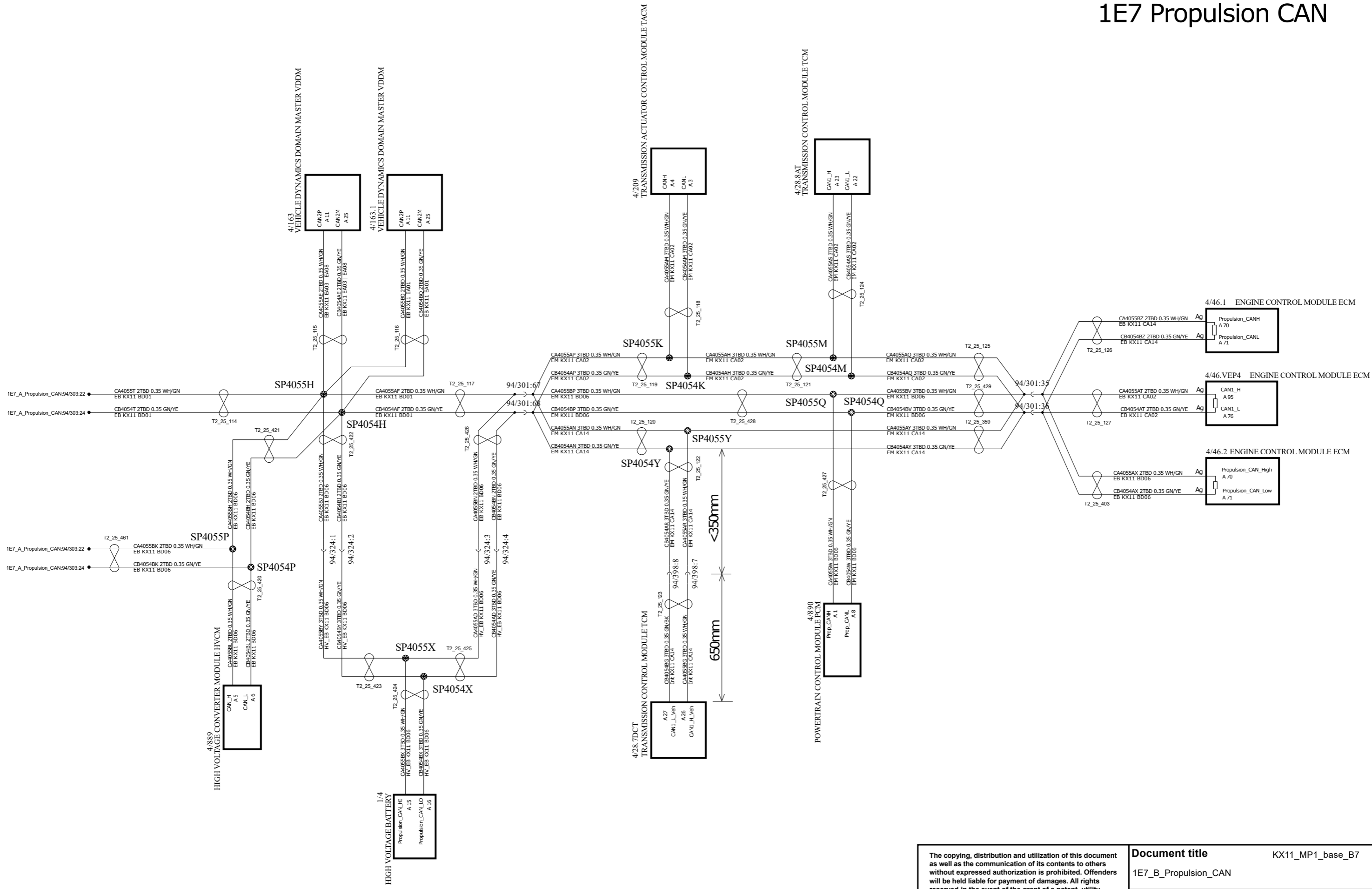

<p>The copying, distribution and utilization of this document as well as the communication of its contents to others without expressed authorization is prohibited. Offenders will be held liable for payment of damages. All rights reserved in the event of the grant of a patent, utility model or ornamental design registration.</p>		<p>Document title KX11_MP1_base_B7</p>	
		<p>1E7_B_Propulsion_CAN</p>	
<p>Document Type DRAW/ELSY</p>		<p>Release Status Released</p>	
<p>Document No 8889755035</p>		<p>Edited March/03/2021</p>	
<p>Issue 007</p>		<p>Page No 21/83</p>	

GEELY

1E8 CAN FD

CAN_FD1

CAN_FD2

CAN_FD3

CAN_FD4

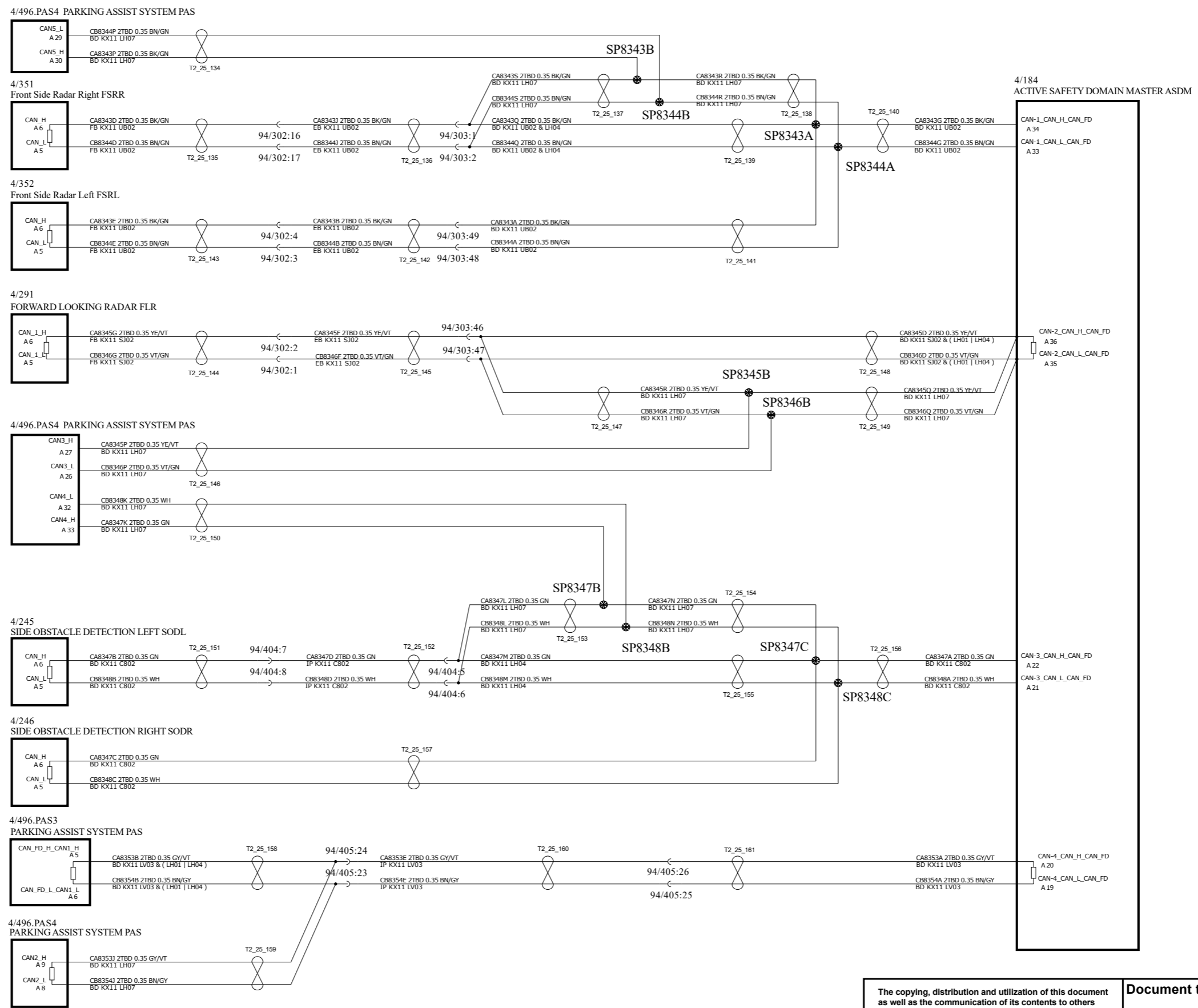

The copying, distribution and utilization of this document as well as the communication of its contents to others without expressed authorization is prohibited. Offenders will be held liable for payment of damages. All rights reserved in the event of the grant of a patent, utility model or ornamental design registration.

GEELY

Document title		KX11_MP1_base_B7	
1E8_CAN_FD			
Document Type	DRAW/ELSY	Release Status	Released
Document No	8889755035	Edited	March/15/2021
Issue	007	Page No	22/83

1E10 Connectivity CAN

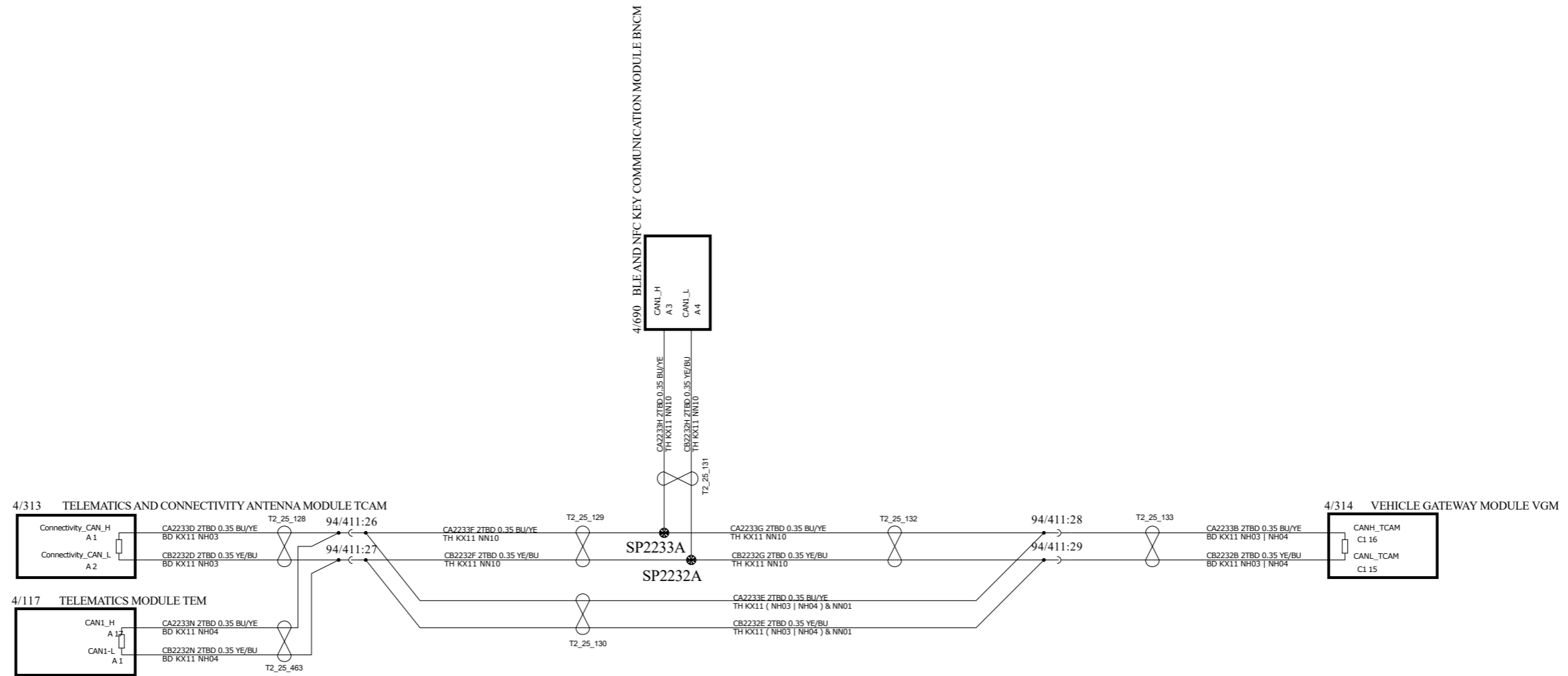

<p>The copying, distribution and utilization of this document as well as the communication of its contents to others without expressed authorization is prohibited. Offenders will be held liable for payment of damages. All rights reserved in the event of the grant of a patent, utility model or ornamental design registration.</p> <p style="text-align: center;">GEELY</p>	Document title KX11_MP1_base_B7 1E10_Connectivity_CAN	
	Document Type DRAW/ELSY	Release Status Released
	Document No 8889755035	Edited April/16/2021
	Issue 007	Page No 23/83

1E11 Private Info CAN

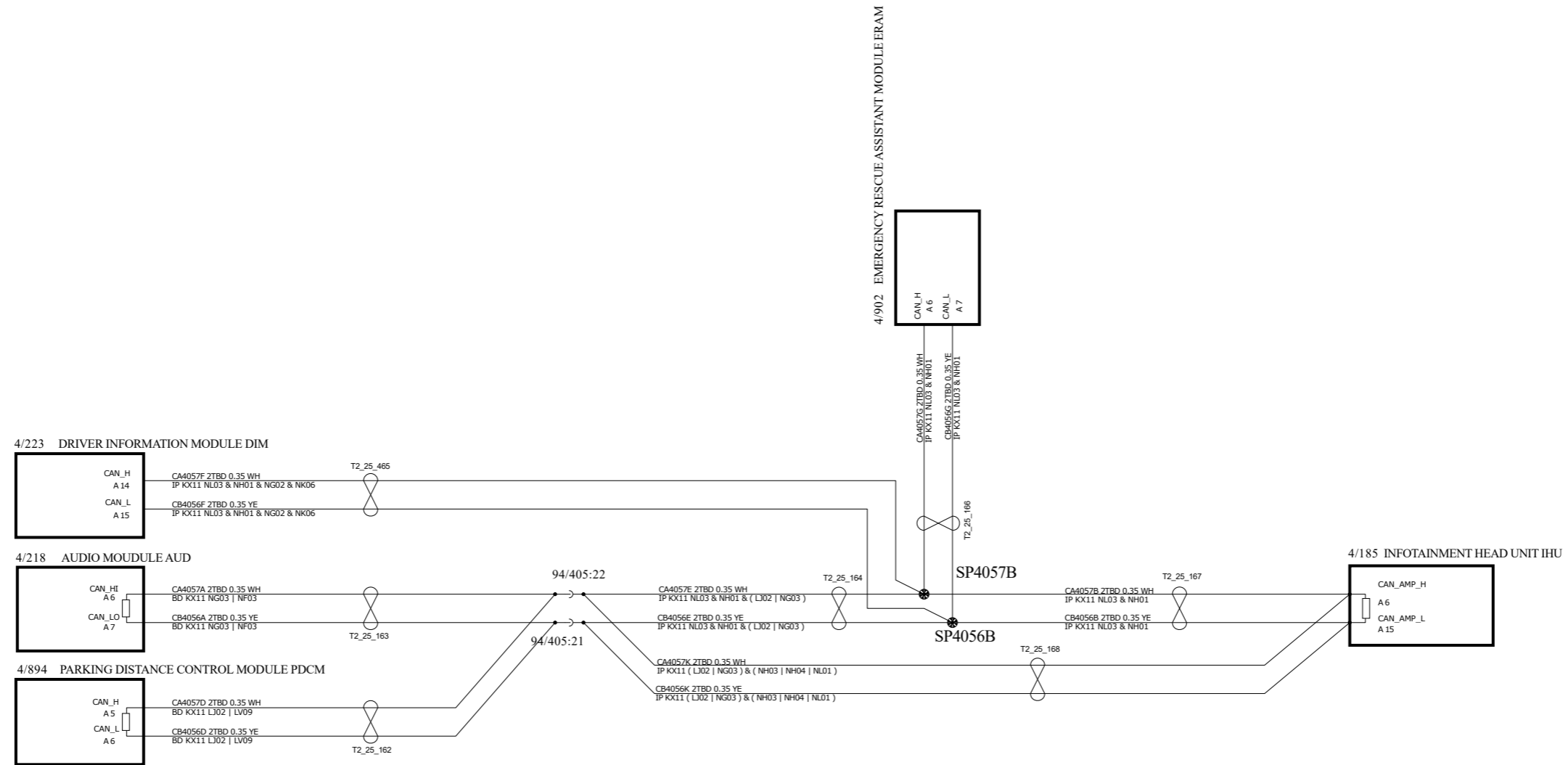

<p>The copying, distribution and utilization of this document as well as the communication of its contents to others without expressed authorization is prohibited. Offenders will be held liable for payment of damages. All rights reserved in the event of the grant of a patent, utility model or ornamental design registration.</p> <p style="text-align: center;">GEELY</p>	Document title KX11_MP1_base_B7 1E11_Private_CAN	
	Document Type DRAW/ELSY	Release Status Released
	Document No 8889755035	Edited June/18/2021
	Issue 007	Page No 24/83

1E13 Ethernet

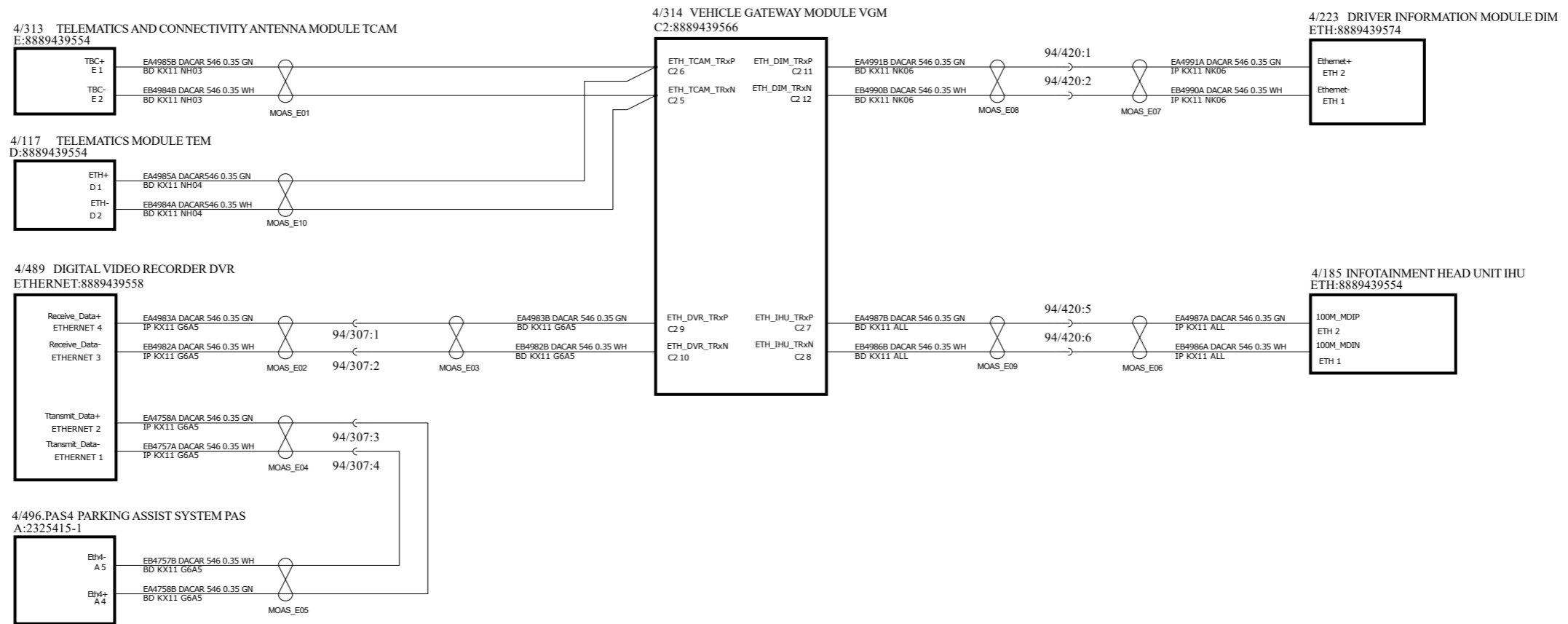

GEELY	Document title KX11_MP1_base_B7	
	1E13_Ethernet	
	Document Type DRAW/ELSY	Release Status Released
	Document No 8889755035	Edited April/16/2021
	Issue 007	Page No 25/83

1E14 ECM LIN

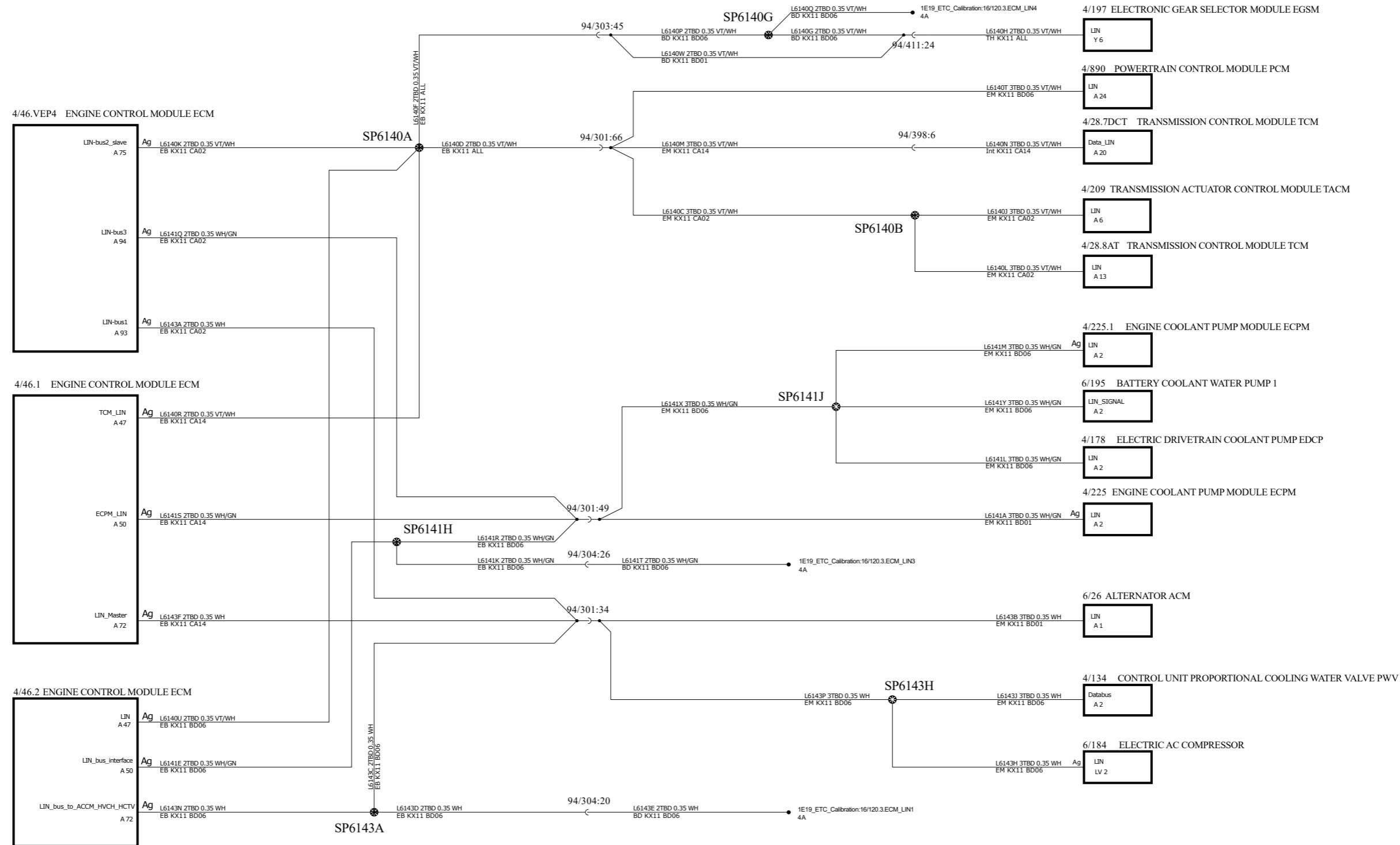

<p>The copying, distribution and utilization of this document as well as the communication of its contents to others without expressed authorization is prohibited. Offenders will be held liable for payment of damages. All rights reserved in the event of the grant of a patent, utility model or ornamental design registration.</p> <p style="text-align: center; font-size: 24pt; font-weight: bold;">GEELY</p>	Document title KX11_MP1_base_B7	
	1E14_ECM_LIN	
	Document Type DRAW/ELSY	Release Status Released
	Document No 8889755035	Edited April/16/2021
	Issue 007	Page No 26/83

1E15 CEM LIN

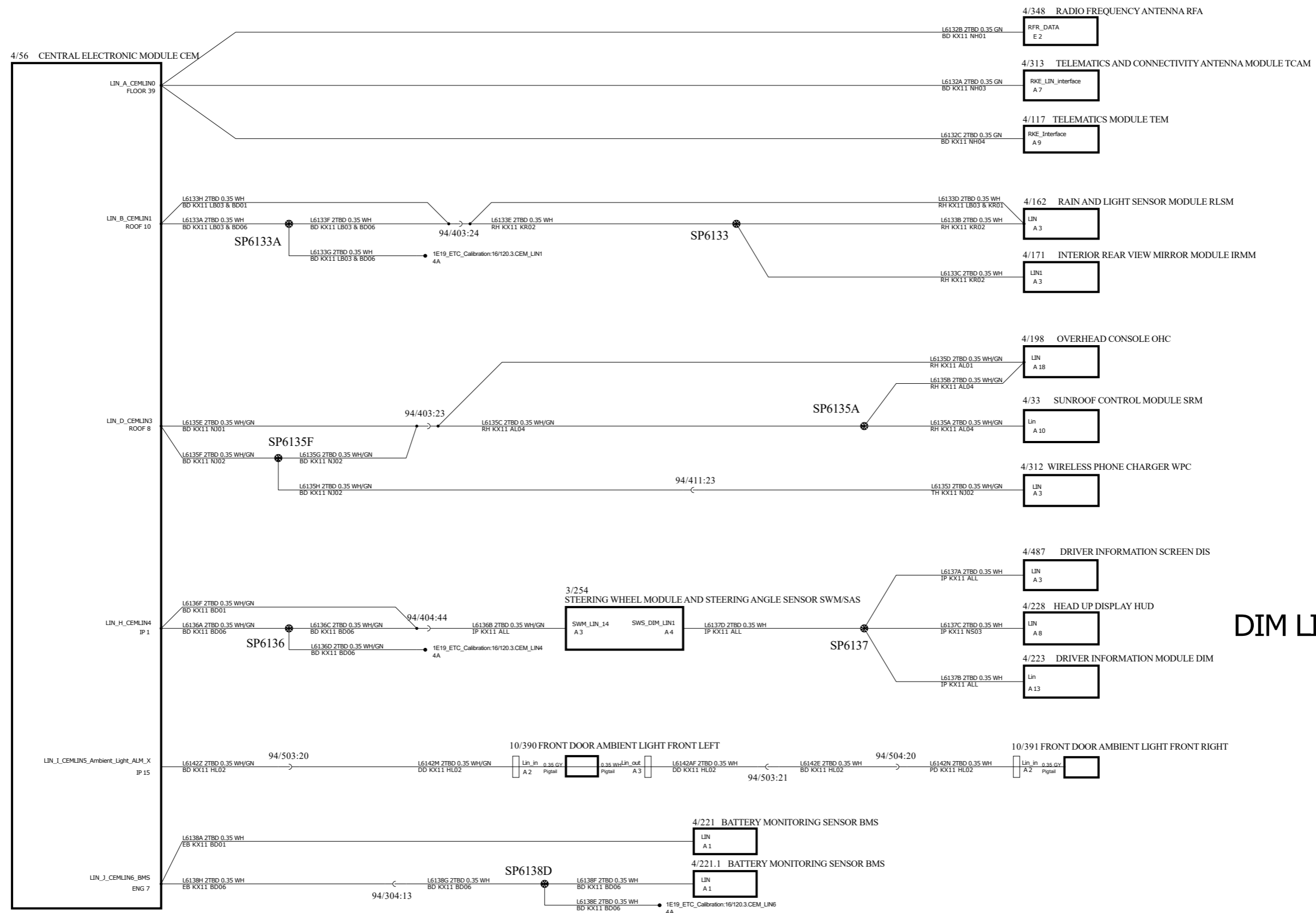

DIM LIN

The copying, distribution and utilization of this document as well as the communication of its contents to others without expressed authorization is prohibited. Offenders will be held liable for payment of damages. All rights reserved in the event of the grant of a patent, utility model or ornamental design registration.

GEELY

Document title		KX11_MP1_base_B7	
1E15_CEM_LIN			
Document Type	DRAW/ELSY	Release Status	Released
Document No	8889755035	Edited	October/21/2021
Issue	007	Page No	27/83

1E16 Comfort LIN

IHU LIN

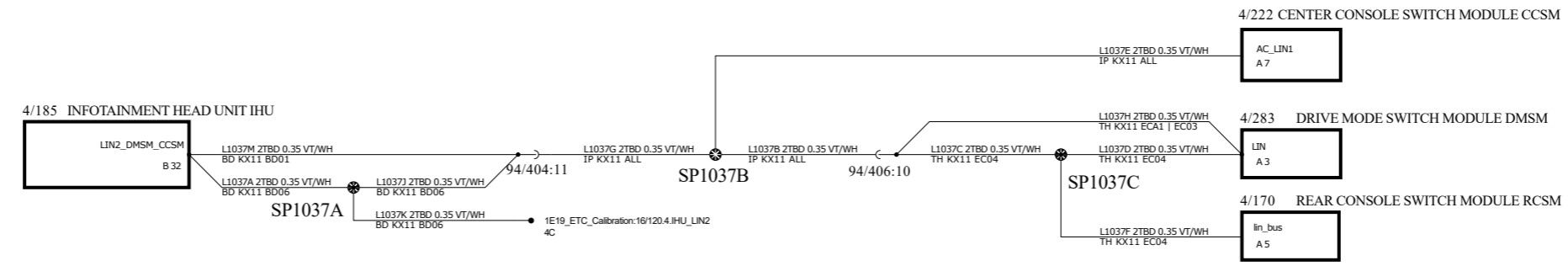

CCM LIN

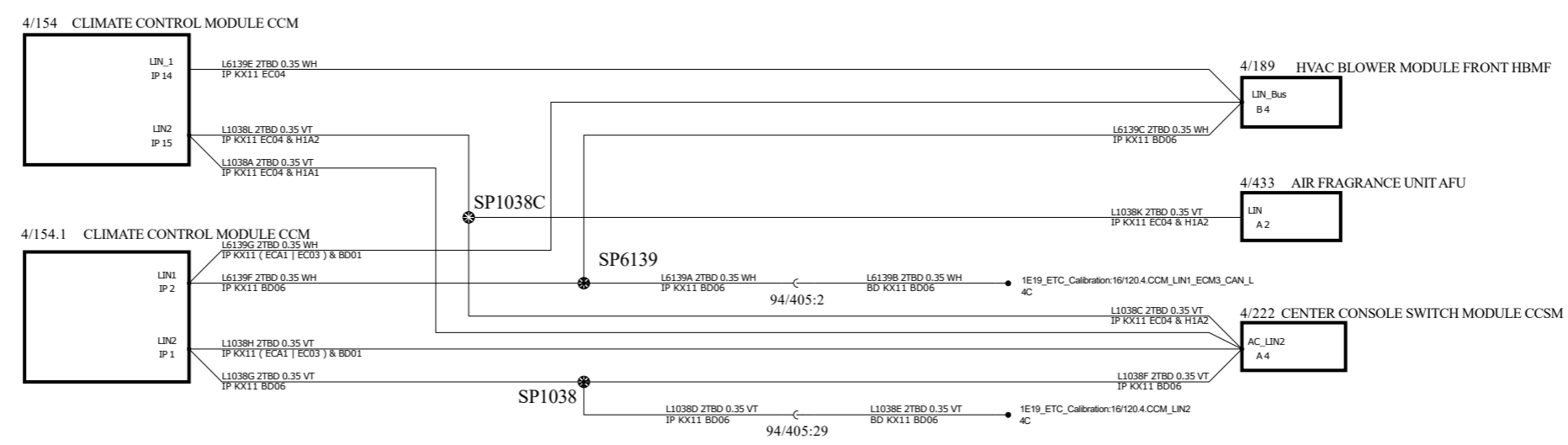

<p>The copying, distribution and utilization of this document as well as the communication of its contents to others without expressed authorization is prohibited. Offenders will be held liable for payment of damages. All rights reserved in the event of the grant of a patent, utility model or ornamental design registration.</p> <p style="text-align: center; font-size: 24px; font-weight: bold;">GEELY</p>	<p>Document title KX11_MP1_base_B7</p> <p>1E16_Comfort_LIN</p>	
	<p>Document Type DRAW/ELSY</p>	<p>Release Status Released</p>
	<p>Document No 8889755035</p>	<p>Edited September/22/2021</p>
	<p>Issue 007</p>	<p>Page No 28/83</p>

1E19 ETC Calibration

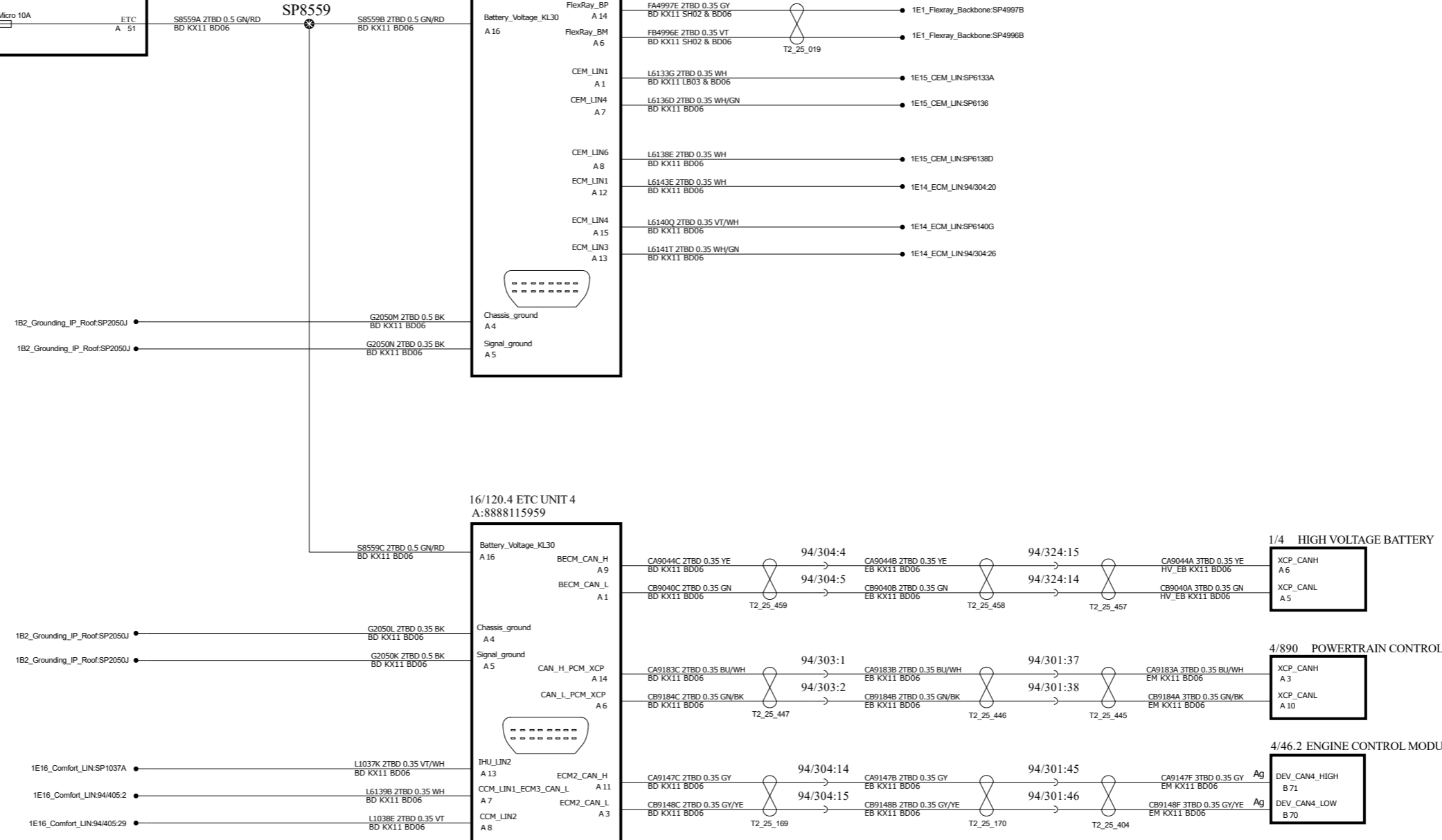
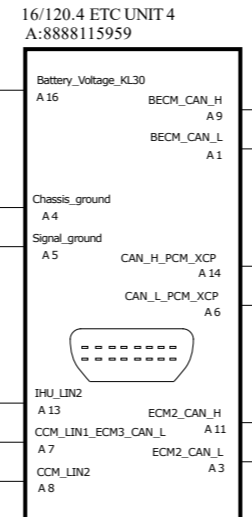
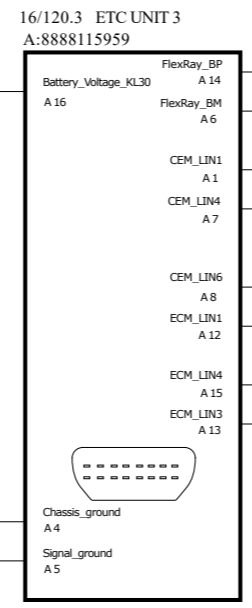
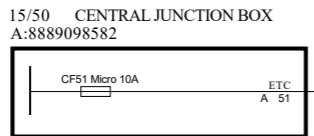

The copying, distribution and utilization of this document as well as the communication of its contents to others without expressed authorization is prohibited. Offenders will be held liable for payment of damages. All rights reserved in the event of the grant of a patent, utility model or ornamental design registration.

GEELY

Document title 1E19_ETC_Calibration		KX11_MP1_base_B7	
Document Type DRAW/ELSY	Release Status Released		
Document No 8889755035		Edited March/01/2021	
Issue 007		Page No 29/83	

1E20 ETC Tadapter Harness

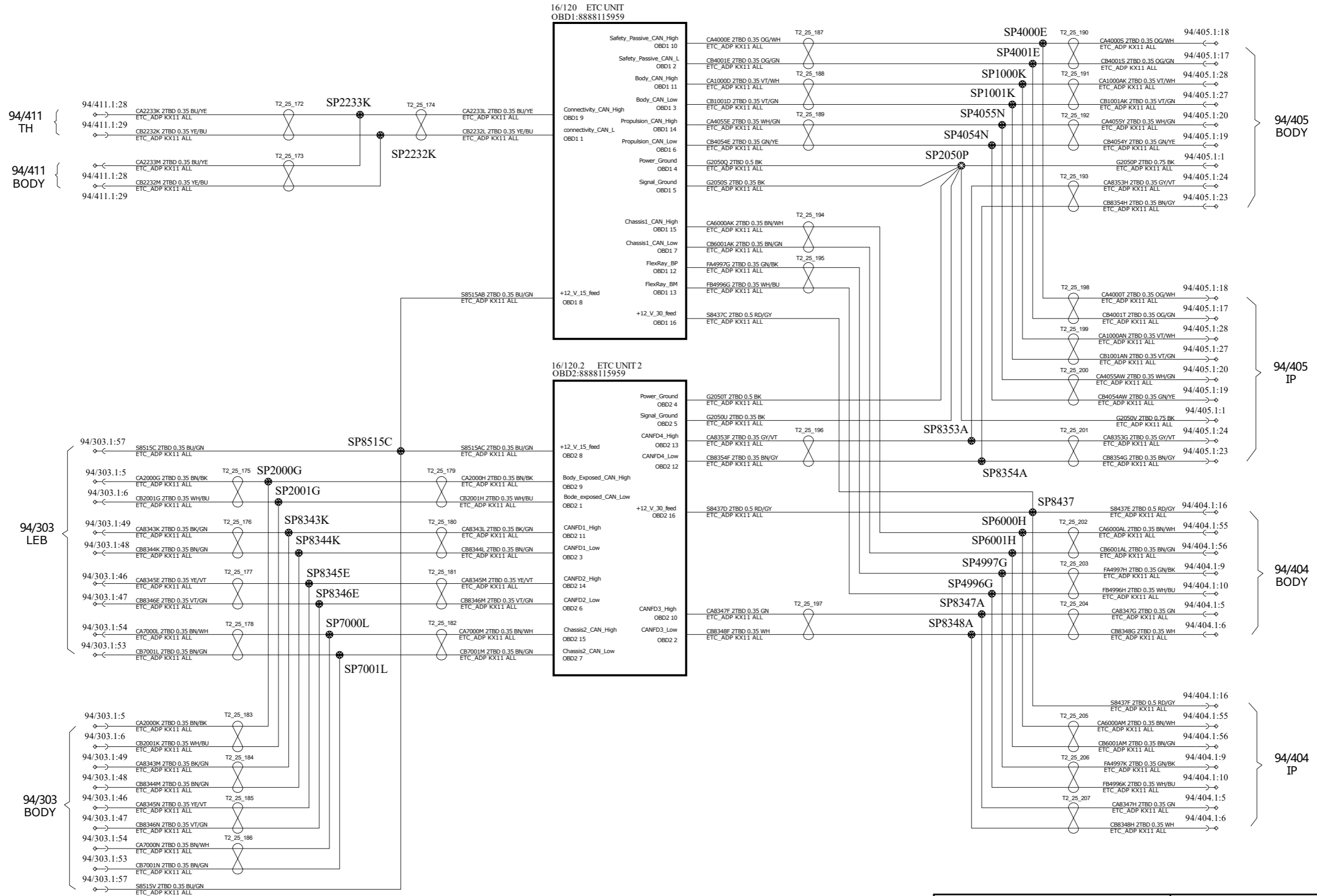

<p>The copying, distribution and utilization of this document as well as the communication of its contents to others without expressed authorization is prohibited. Offenders will be held liable for payment of damages. All rights reserved in the event of the grant of a patent, utility model or ornamental design registration.</p> <h2 style="margin: 0;">GEELY</h2>	Document title KX11_MP1_base_B7	
	1E20_A_ETC_Tadapter_Harness	
	Document Type DRAW/ELSY	Release Status Released
	Document No 8889755035	Edited December/04/2020
Issue 007	Page No 30/83	

1E20 ETC Tadapter Harness

94/303.1

94/404.1

94/405.1

94/411.1

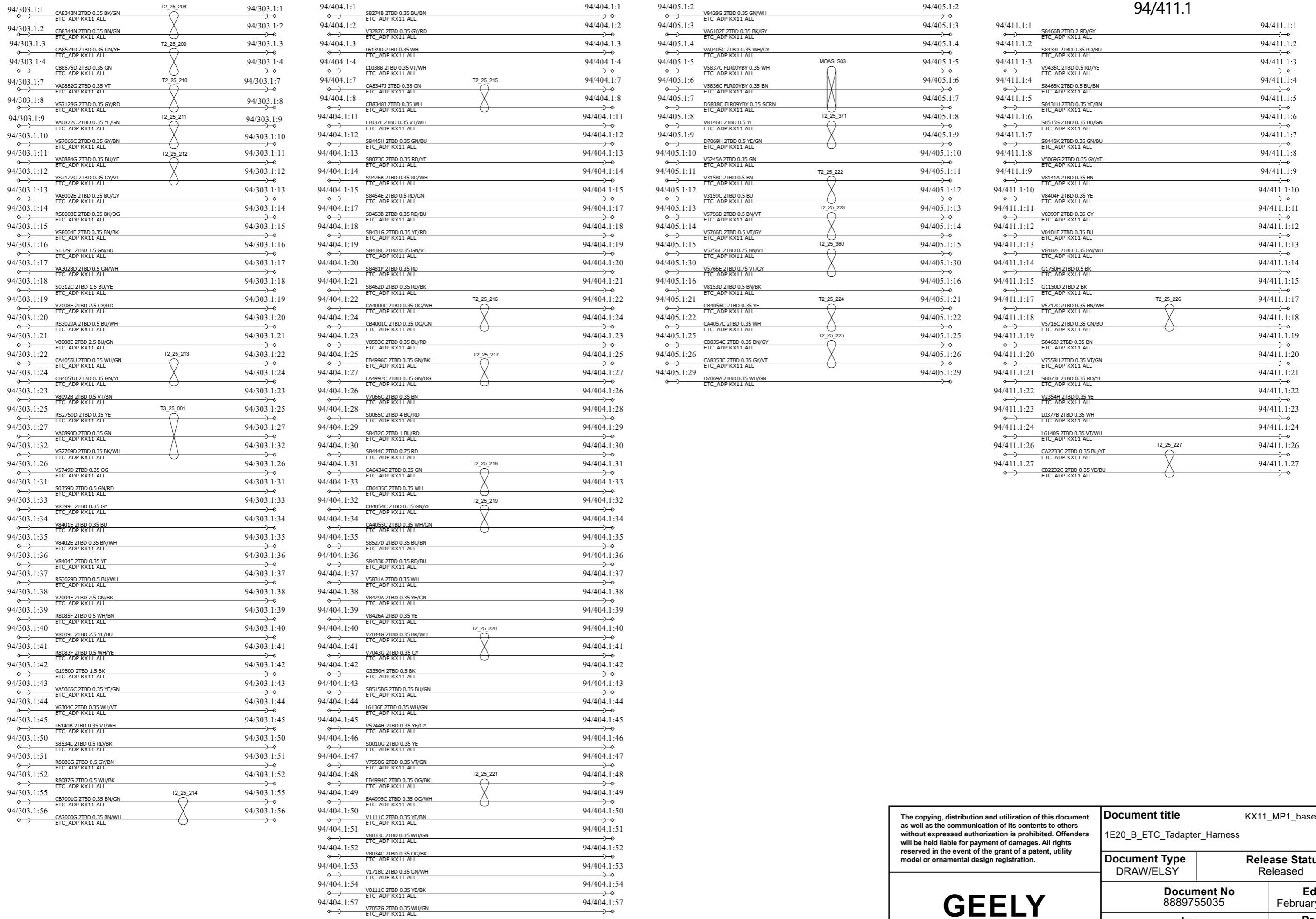

The copying, distribution and utilization of this document as well as the communication of its contents to others without expressed authorization is prohibited. Offenders will be held liable for payment of damages. All rights reserved in the event of the grant of a patent, utility model or ornamental design registration.



Document title 1E20_B_ETC_Tadapter_Harness		KX11_MP1_base_B7	
Document Type DRAW/ELSY	Release Status Released		
Document No 8889755035		Edited February/24/2021	
Issue 007		Page No 31/83	

2A1 Braking VDDM F-LD

15/49 ENGINE JUNCTION BOX
EJB1 B:8889434927
EJB1 C:8889694514

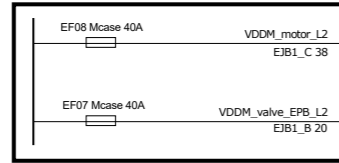

4/163 VEHICLE DYNAMICS DOMAIN MASTER VDDM
A:8890397727

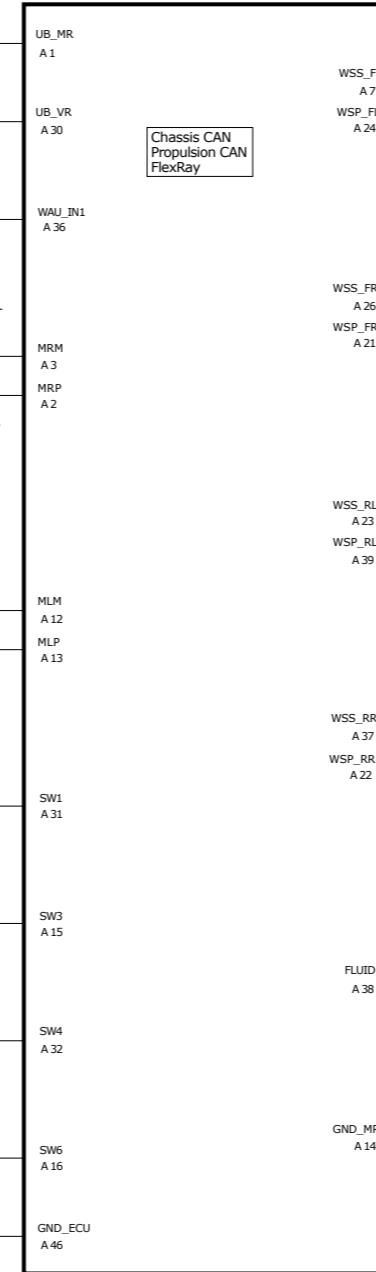

6/147 BRAKE CALIPER MOTOR RH REAR
A:888118429

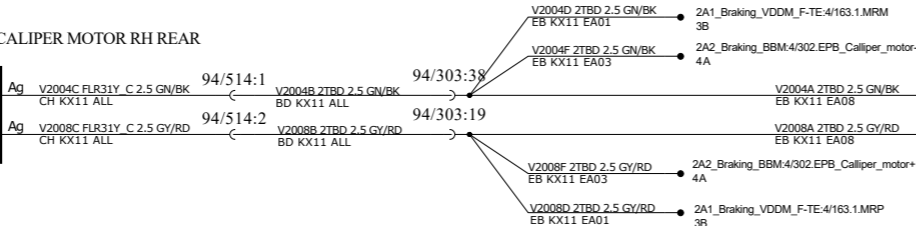
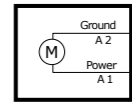

6/146 BRAKE CALIPER MOTOR LH REAR
A:888118429

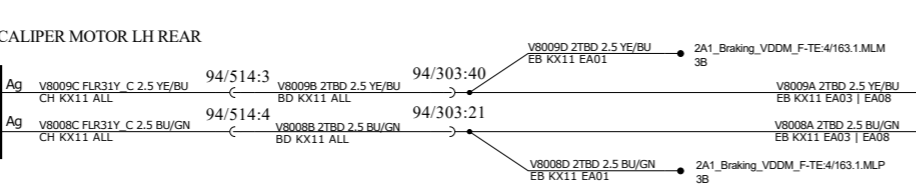
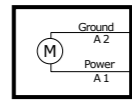

3/272 ELECTRONIC PARKING BRAKE SWITCH
A:8889627667

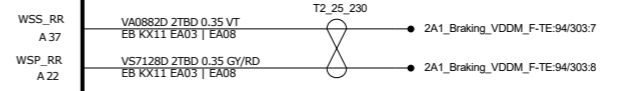
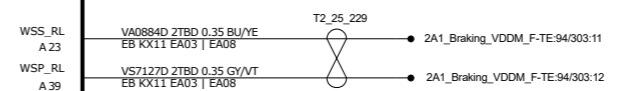
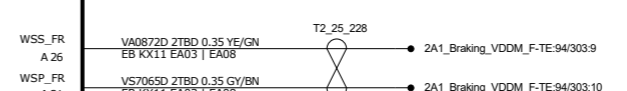
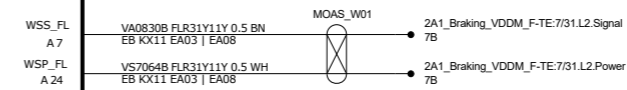
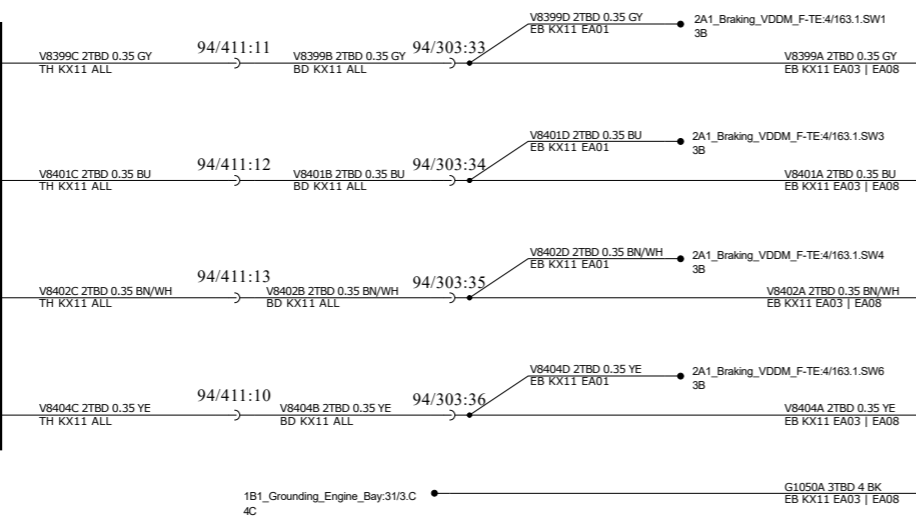
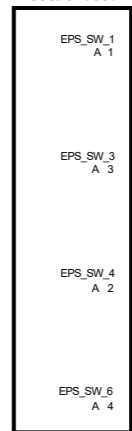

7/4.1 BRAKE FLUID LEVEL SENSOR
A:888118120

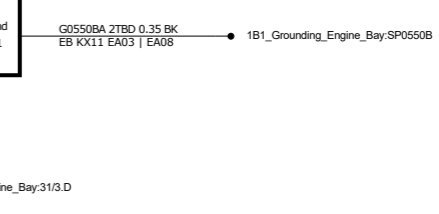
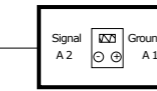

<p>The copying, distribution and utilization of this document as well as the communication of its contents to others without expressed authorization is prohibited. Offenders will be held liable for payment of damages. All rights reserved in the event of the grant of a patent, utility model or ornamental design registration.</p> <p style="text-align: center; font-size: 24pt; font-weight: bold;">GEELY</p>	<p>Document title KX11_MP1_base_B7</p> <p>2A1_Braking_VDDM_F-LD</p>	
	<p>Document Type DRAW/ELSY</p>	<p>Release Status Released</p>
	<p>Document No 8889755035</p>	<p>Edited December/28/2020</p>
	<p>Issue 007</p>	<p>Page No 32/83</p>

2A1 Braking VDDM F-TE

15/49 ENGINE JUNCTION BOX
EJB1 B:8889434927
EJB1 C:8889694514

4/163.1 VEHICLE DYNAMICS DOMAIN MASTER VDDM
A:8890397727

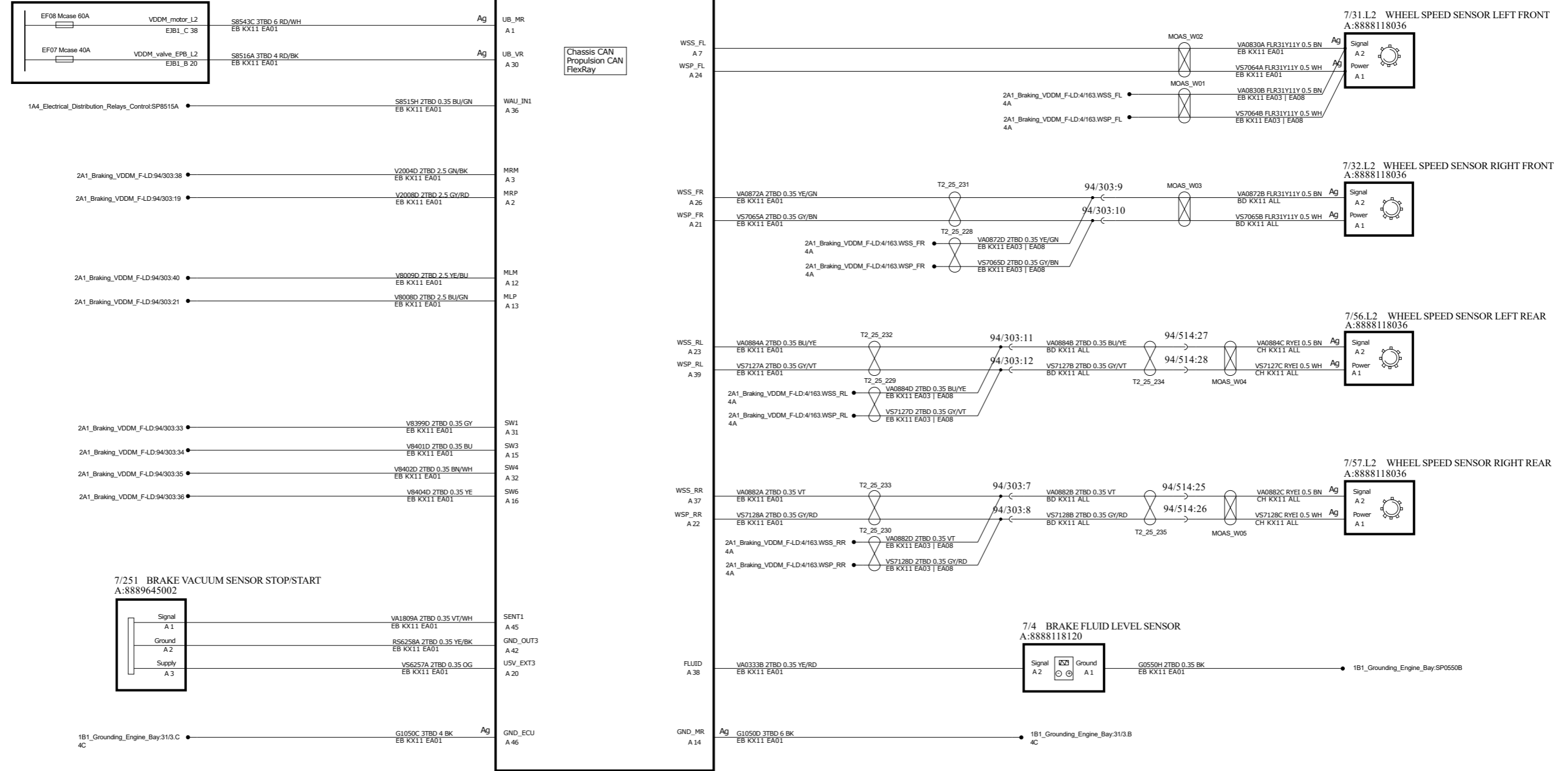

The copying, distribution and utilization of this document as well as the communication of its contents to others without expressed authorization is prohibited. Offenders will be held liable for payment of damages. All rights reserved in the event of the grant of a patent, utility model or ornamental design registration.

GEELY

Document title 2A1_Braking_VDDM_F-TE		KX11_MP1_base_B7	
Document Type DRAW/ELSY	Release Status Released		
Document No 8889755035		Edited April/01/2021	
Issue 007		Page No 33/83	

2A2 Braking BBM

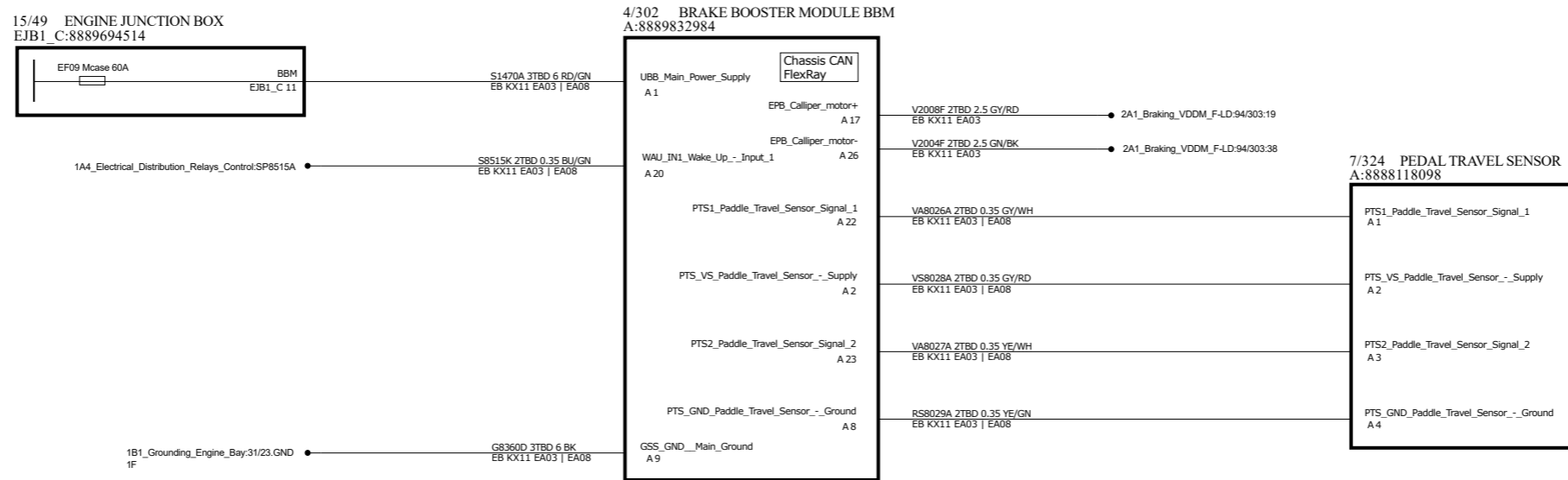

<p>The copying, distribution and utilization of this document as well as the communication of its contents to others without expressed authorization is prohibited. Offenders will be held liable for payment of damages. All rights reserved in the event of the grant of a patent, utility model or ornamental design registration.</p> <p style="text-align: center;">GEELY</p>	Document title KX11_MP1_base_B7 2A2_Braking_BBM	
	Document Type DRAW/ELSY	Release Status Released
	Document No 8889755035	Edited January/20/2021
	Issue 007	Page No 34/83

2B Collision Avoidance

15/50 CENTRAL JUNCTION BOX
A:8889098582

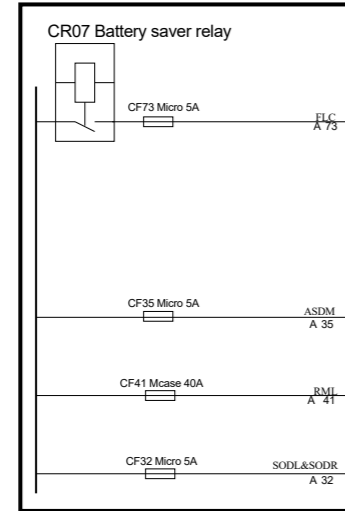

15/49 ENGINE JUNCTION BOX
EJB1 B:8889434927
EJB1 D:8889694512

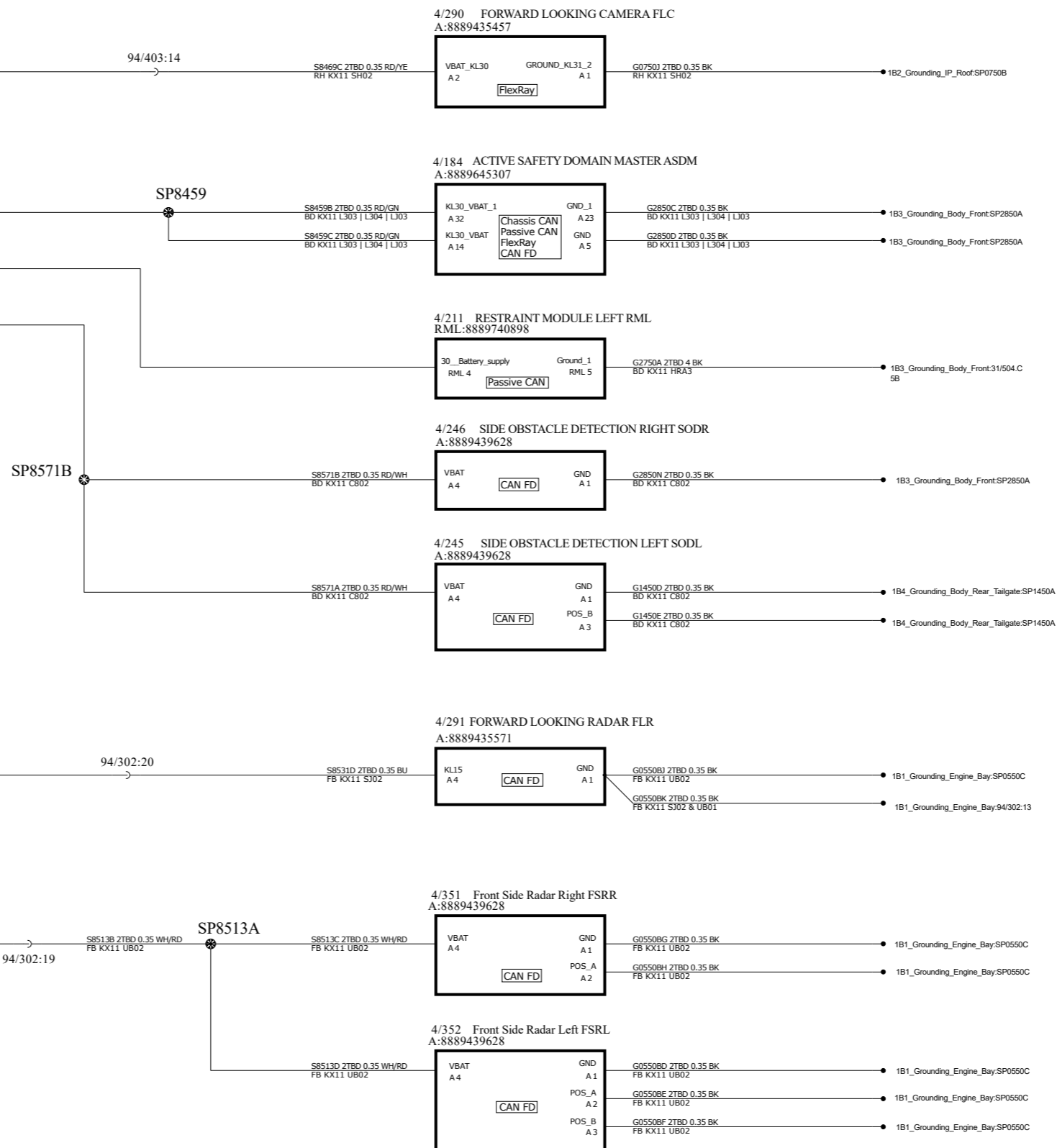
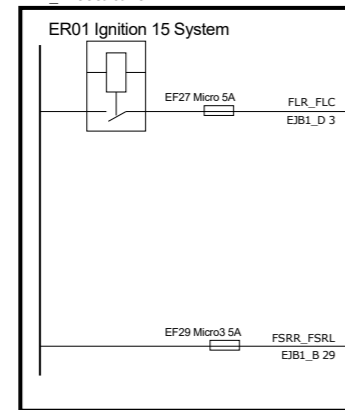

The copying, distribution and utilization of this document as well as the communication of its contents to others without expressed authorization is prohibited. Offenders will be held liable for payment of damages. All rights reserved in the event of the grant of a patent, utility model or ornamental design registration.

GEELY

Document title KX11_MP1_base_B7 2B_Collision_Avoidance	
Document Type DRAW/ELSY	Release Status Released
Document No 8889755035	Edited April/16/2021
Issue 007	Page No 35/83

2C1 Supplementary Restraint System

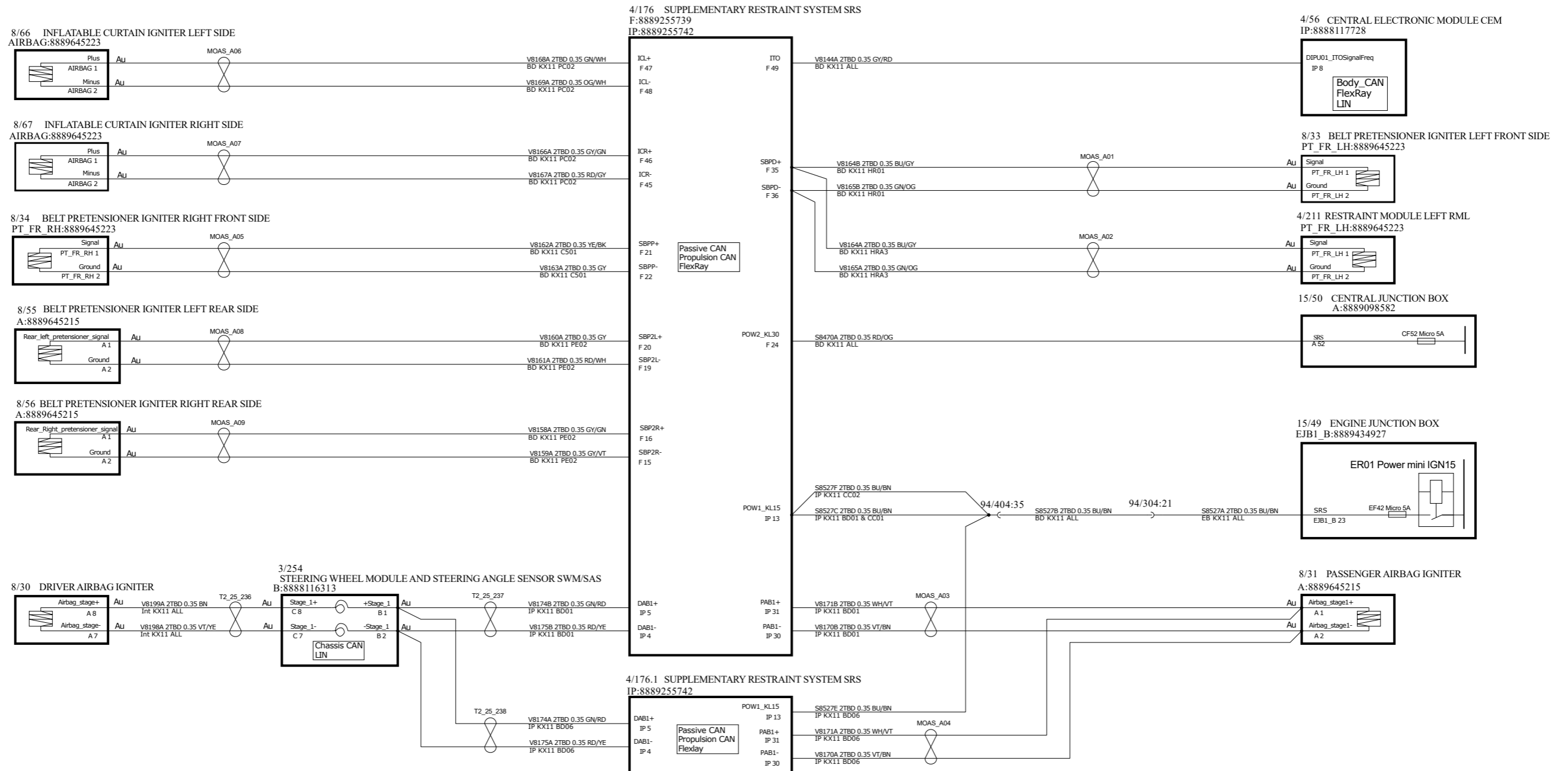

GEELY	The copying, distribution and utilization of this document as well as the communication of its contents to others without expressed authorization is prohibited. Offenders will be held liable for payment of damages. All rights reserved in the event of the grant of a patent, utility model or ornamental design registration.		Document title KX11_MP1_base_B7 2C1_A_Supplementary_Restraint_System	
	Document Type DRAW/ELSY	Release Status Released		
	Document No 8889755035		Edited August/27/2021	
	Issue 007		Page No 36/83	

2C1 Supplementary Restraint System

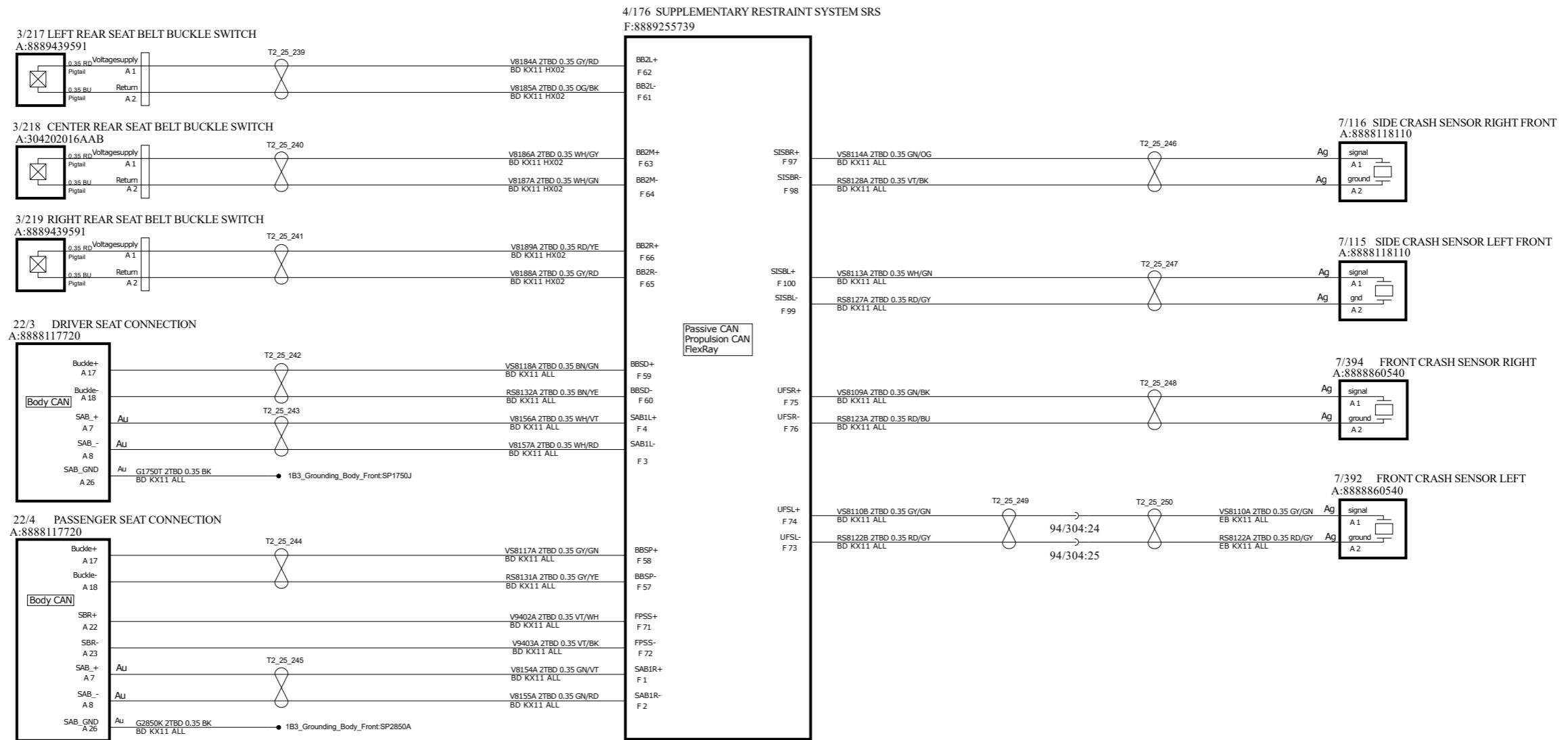

GEELY	Document title KX11_MP1_base_B7 2C1_B_Supplementary_Restraint_System	
	Document Type DRAW/ELSY	Release Status Released
	Document No 8889755035	Edited October/22/2021
	Issue 007	Page No 37/83

2D Power Steering

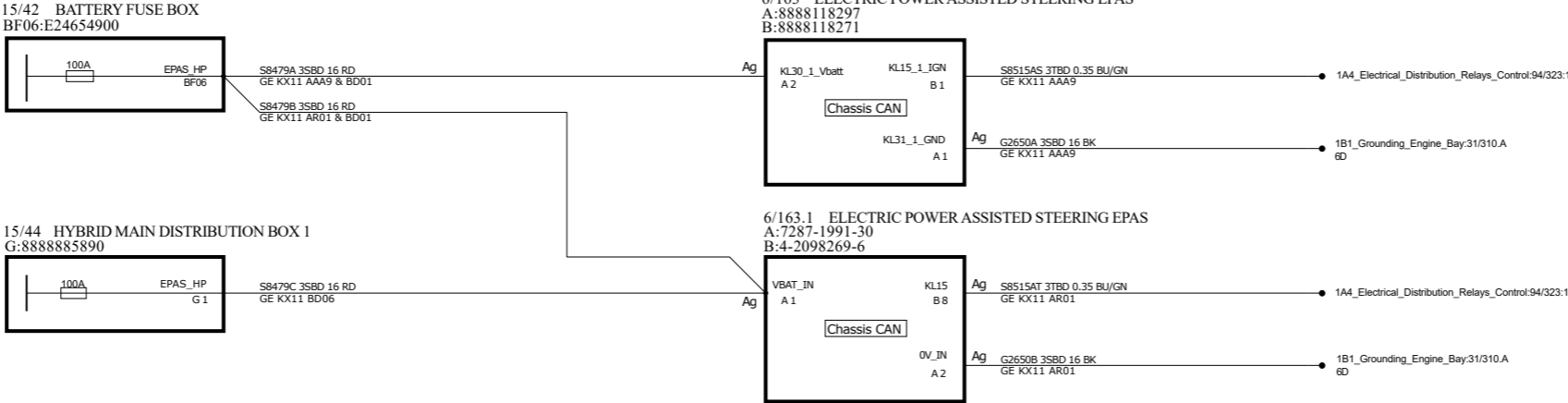

<p>The copying, distribution and utilization of this document as well as the communication of its contents to others without expressed authorization is prohibited. Offenders will be held liable for payment of damages. All rights reserved in the event of the grant of a patent, utility model or ornamental design registration.</p> <p style="text-align: center; font-size: 24pt; font-weight: bold;">GEELY</p>	<p>Document title KX11_MP1_base_B7</p> <p>2D1_Power_Steering</p>	
	<p>Document Type DRAW/ELSY</p>	<p>Release Status Released</p>
	<p>Document No 8889755035</p>	<p>Edited October/21/2021</p>
	<p>Issue 007</p>	<p>Page No 38/83</p>

2D2_Power_Steering_Internal

6/163.2 ELECTRIC POWER ASSISTED STEERING EPAS

Torque_Sensor1_5V C 6	VS8010A 3TBD 0.35 VT Int KX11 ALL
Torque1 C 1	VAB011A 3TBD 0.35 BU Int KX11 ALL
Torque_Sensor1_0V C 2	RS8001A 3TBD 0.35 WH/BK Int KX11 ALL
Torque_Sensor2_5V C 10	VS8014A 3TBD 0.35 RD Int KX11 ALL
Torque2 C 5	VAB015A 3TBD 0.35 BN Int KX11 ALL
Torque_Sensor2_0V C 4	RS8006A 3TBD 0.35 BK Int KX11 ALL
Torque_Sensor3_5V C 8	VS8012A 3TBD 0.35 WH Int KX11 ALL
Torque3 C 3	VAB013A 3TBD 0.35 OG Int KX11 ALL

6/163.INT.2 ELECTRIC POWER ASSISTED STEERING EPAS

Torque_Sensor1_5V A 6
Torque1 A 1
Torque_Sensor1_0V A 2
Torque_Sensor2_5V A 10
Torque2 A 5
Torque_Sensor2_0V A 4
Torque_Sensor3_5V A 8
Torque3 A 3

<p>The copying, distribution and utilization of this document as well as the communication of its contents to others without expressed authorization is prohibited. Offenders will be held liable for payment of damages. All rights reserved in the event of the grant of a patent, utility model or ornamental design registration.</p> <p style="text-align: center;">GEELY</p>	Document title KX11_MP1_base_B7 2D2_Power_Steering_Internal	
	Document Type DRAW/ELSY	Release Status Released
	Document No 8889755035	Edited October/22/2021
	Issue 007	Page No 39/83

3A Engine Management DHE3

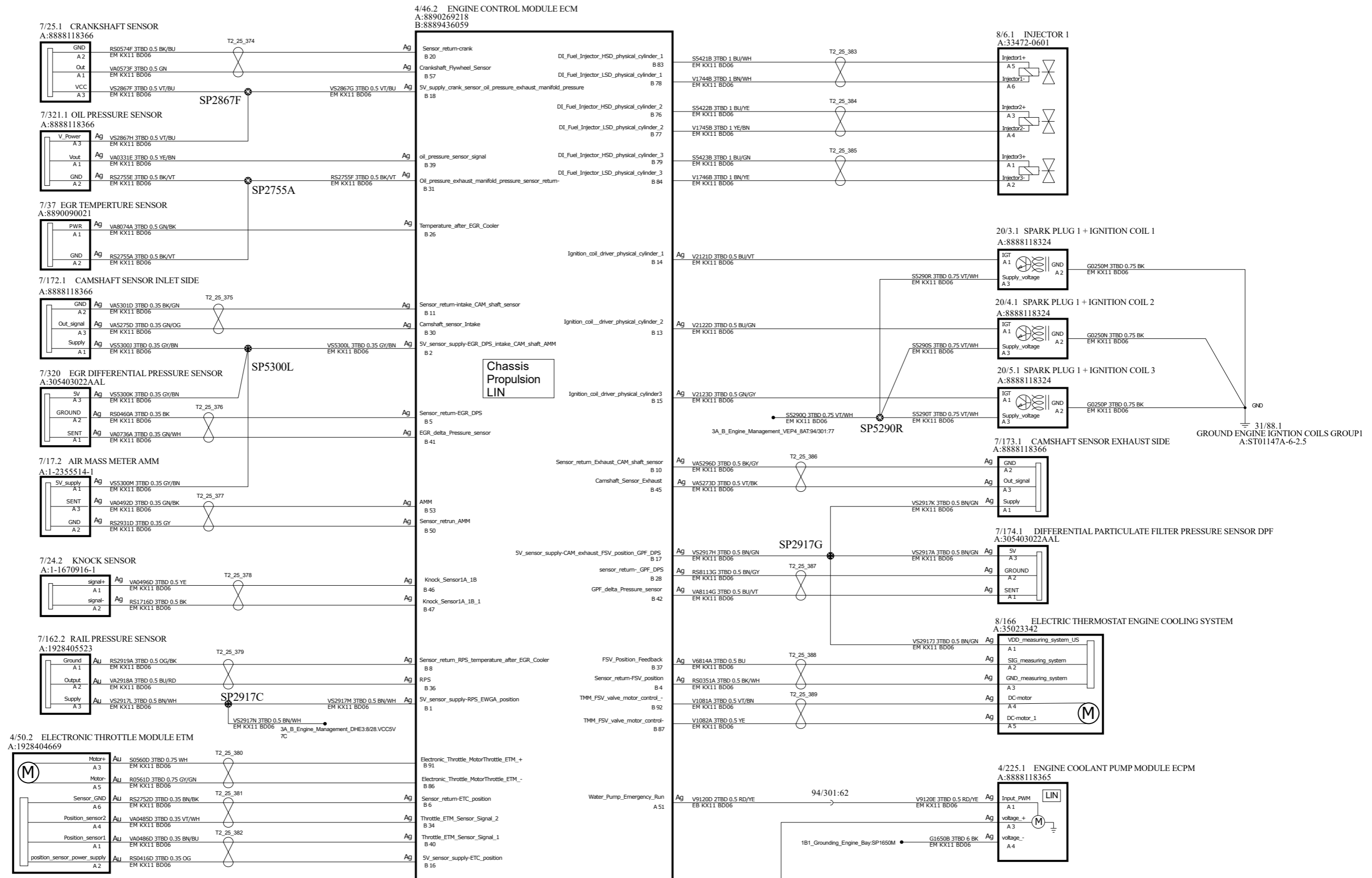

The copying, distribution and utilization of this document as well as the communication of its contents to others without expressed authorization is prohibited. Offenders will be held liable for payment of damages. All rights reserved in the event of the grant of a patent, utility model or ornamental design registration.

Document title KX11_MP1_base_B7 3A_A_Engine_Management_DHE3	
Document Type DRAW/ELSY	Release Status Released
Document No 8889755035	Edited October/19/2021
Issue 007	Page No 40/83

GEELY

3A Engine Management VEP4 7DCT

4/46.1 ENGINE CONTROL MODULE ECM
 A:8890269218
 B:8889436059

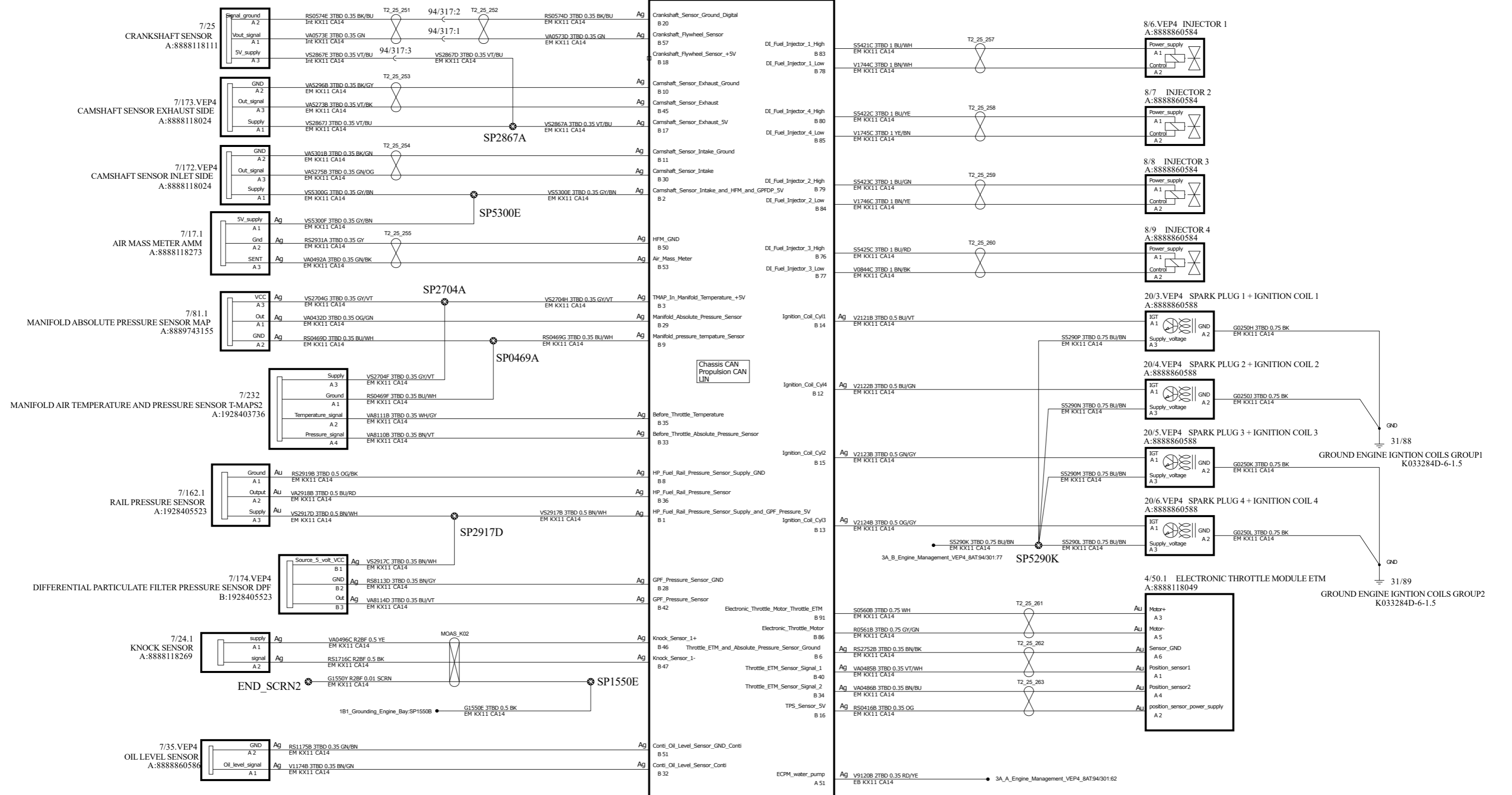

<p>The copying, distribution and utilization of this document as well as the communication of its contents to others without expressed authorization is prohibited. Offenders will be held liable for payment of damages. All rights reserved in the event of the grant of a patent, utility model or ornamental design registration.</p>		<p>Document title KX11_MP1_base_B7 3A_A_Engine_Management_VEP4_7DCT</p>	
		<p>Document Type DRAW/ELSY</p>	<p>Release Status Released</p>
<p>GEELY</p>		<p>Document No 8889755035</p>	<p>Edited August/30/2021</p>
		<p>Issue 007</p>	<p>Page No 41/83</p>

3A Engine Management VEP4 8AT

4/46.VEP4 ENGINE CONTROL MODULE ECM
 A:8889048225
 B:8889048223

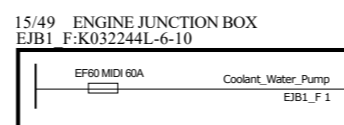
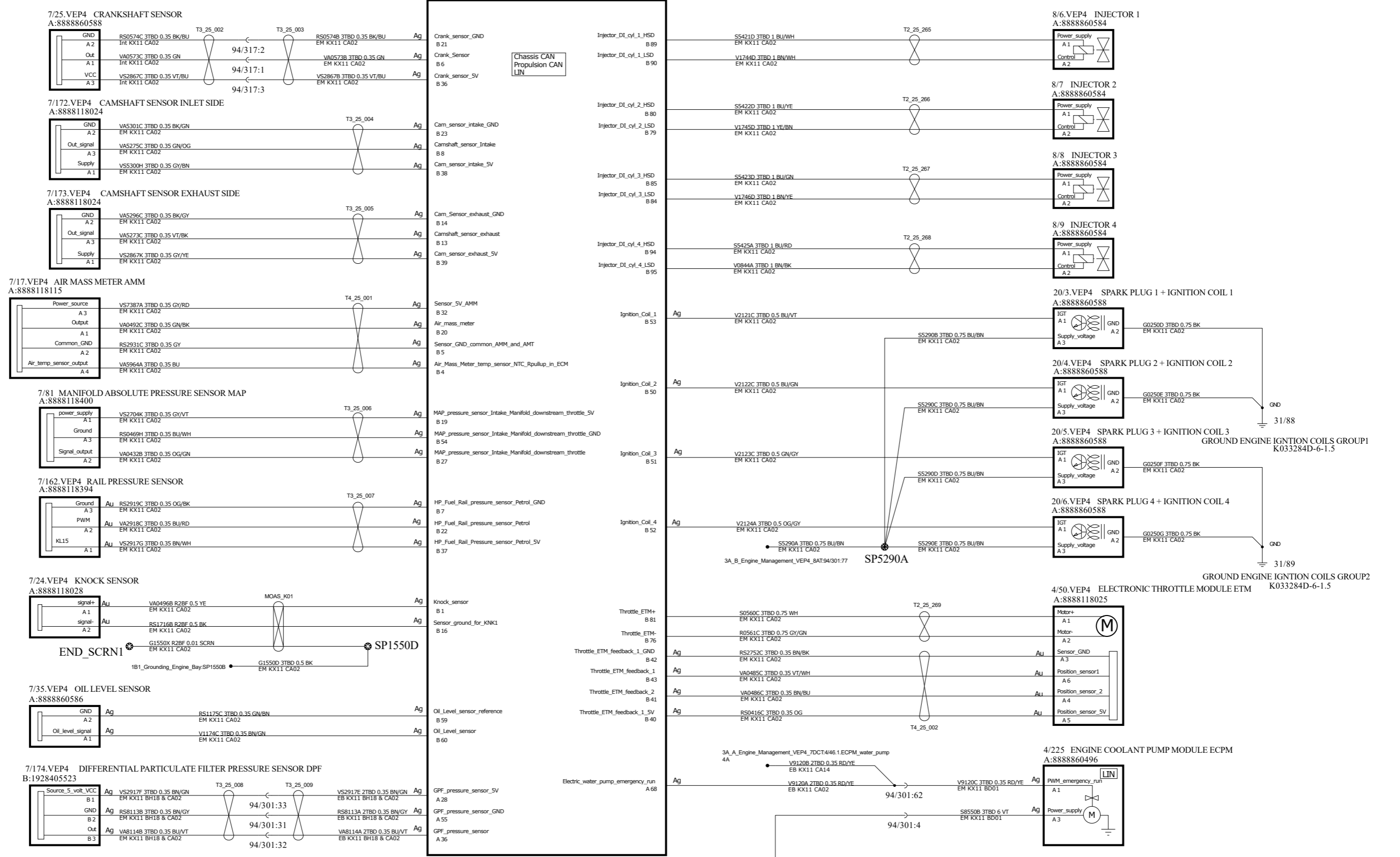

The copying, distribution and utilization of this document as well as the communication of its contents to others without expressed authorization is prohibited. Offenders will be held liable for payment of damages. All rights reserved in the event of the grant of a patent, utility model or ornamental design registration.

GEELY

Document title		KX11_MP1_base_B7	
3A_A_Engine_Management_VEP4_8AT			
Document Type	DRAW/ELSY	Release Status	Released
Document No	8889755035	Edited	May/14/2021
Issue	007	Page No	42/83

3A Engine Management DHE3

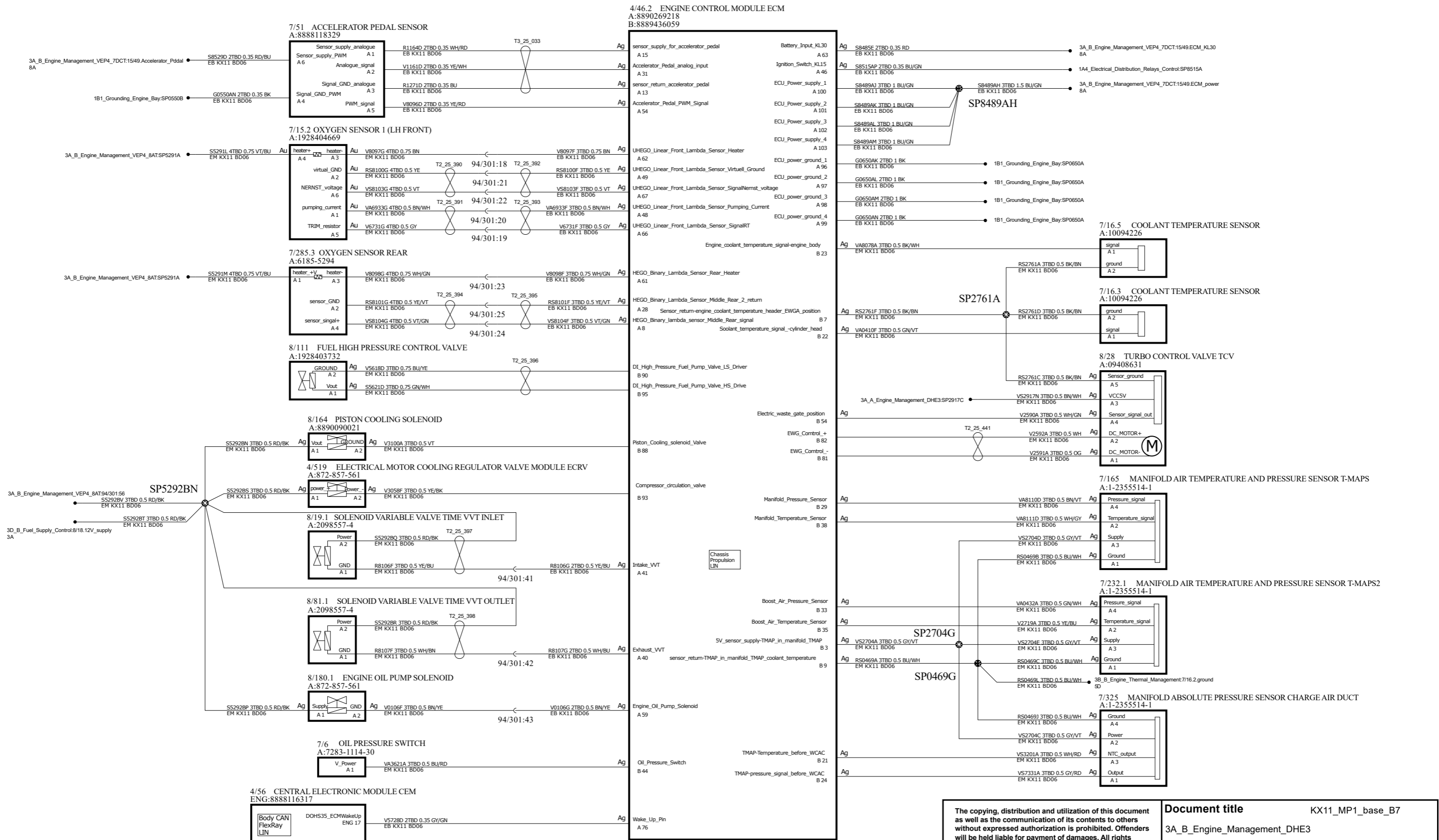

The copying, distribution and utilization of this document as well as the communication of its contents to others without expressed authorization is prohibited. Offenders will be held liable for payment of damages. All rights reserved in the event of the grant of a patent, utility model or ornamental design registration.

GEELY

Document title KX11_MP1_base_B7 3A_B_Engine_Management_DHE3	
Document Type DRAW/ELSY	Release Status Released
Document No 8889755035	Edited October/19/2021
Issue 007	Page No 43/83

3A Engine Management VEP4 7DCT

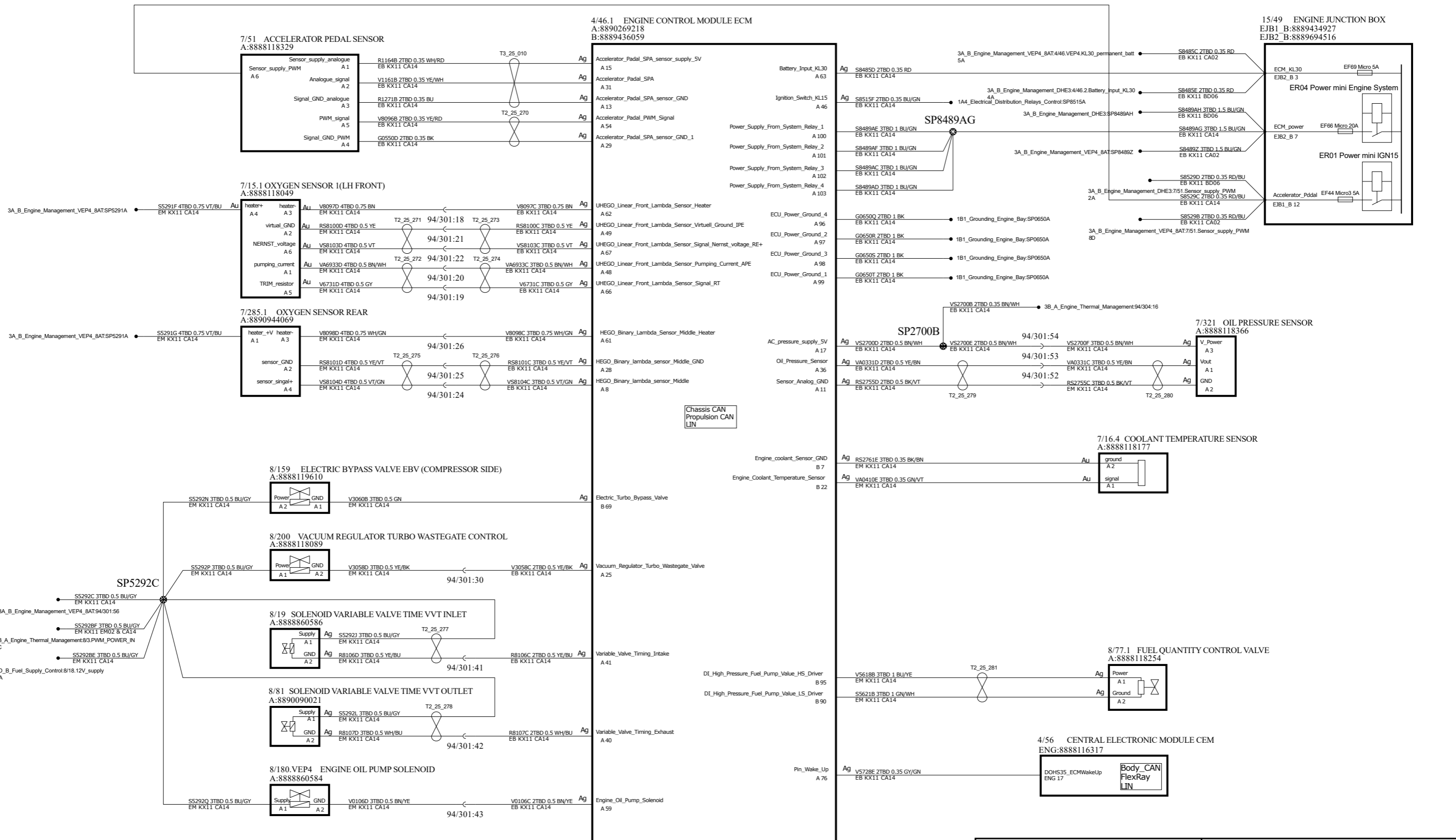

<p>The copying, distribution and utilization of this document as well as the communication of its contents to others without expressed authorization is prohibited. Offenders will be held liable for payment of damages. All rights reserved in the event of the grant of a patent, utility model or ornamental design registration.</p> <p style="text-align: center; font-size: 2em; font-weight: bold;">GEELY</p>		Document title KX11_MP1_base_B7 3A_B_Engine_Management_VEP4_7DCT	
		Document Type DRAW/ELSY	Release Status Released
		Document No 8889755035	Edited December/04/2020
		Issue 007	Page No 44/83

3A Engine Management VEP4 8AT

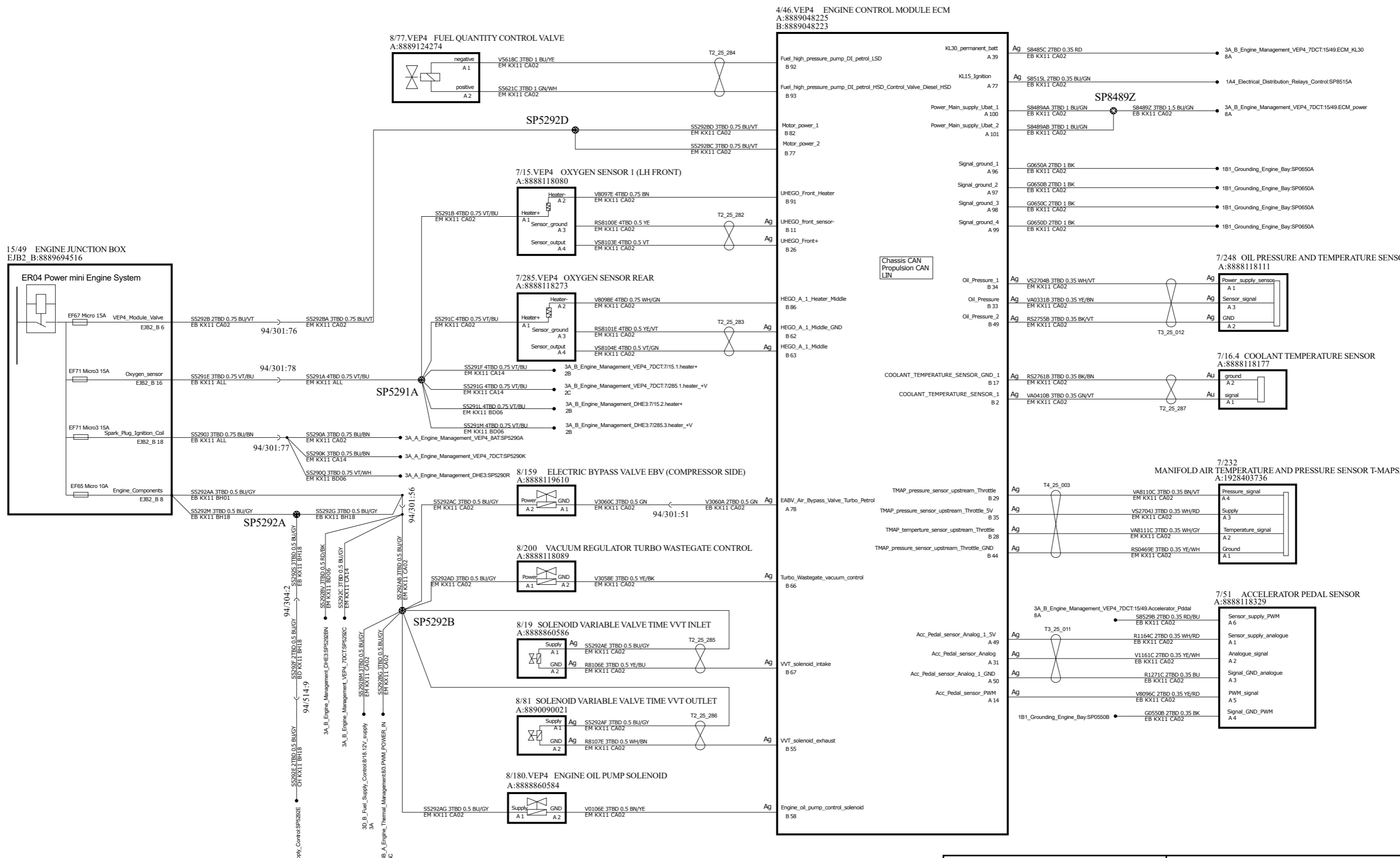

<p>The copying, distribution and utilization of this document as well as the communication of its contents to others without expressed authorization is prohibited. Offenders will be held liable for payment of damages. All rights reserved in the event of the grant of a patent, utility model or ornamental design registration.</p>		<p>Document title KX11_MP1_base_B7 3A_B_Engine_Management_VEP4_8AT</p>	
		<p>Document Type DRAW/ELSY</p>	<p>Release Status Released</p>
<p>GEELY</p>		<p>Document No 8889755035</p>	<p>Edited March/01/2021</p>
		<p>Issue 007</p>	<p>Page No 45/83</p>

3B Engine Thermal Management

15/49 ENGINE JUNCTION BOX
 EJB1_C:8889694514
 EJB1_D:8889694512
 EJB1_E:K032244L-6-10
 EJB2_A:PP1531614
 EJB2_B:8889694516

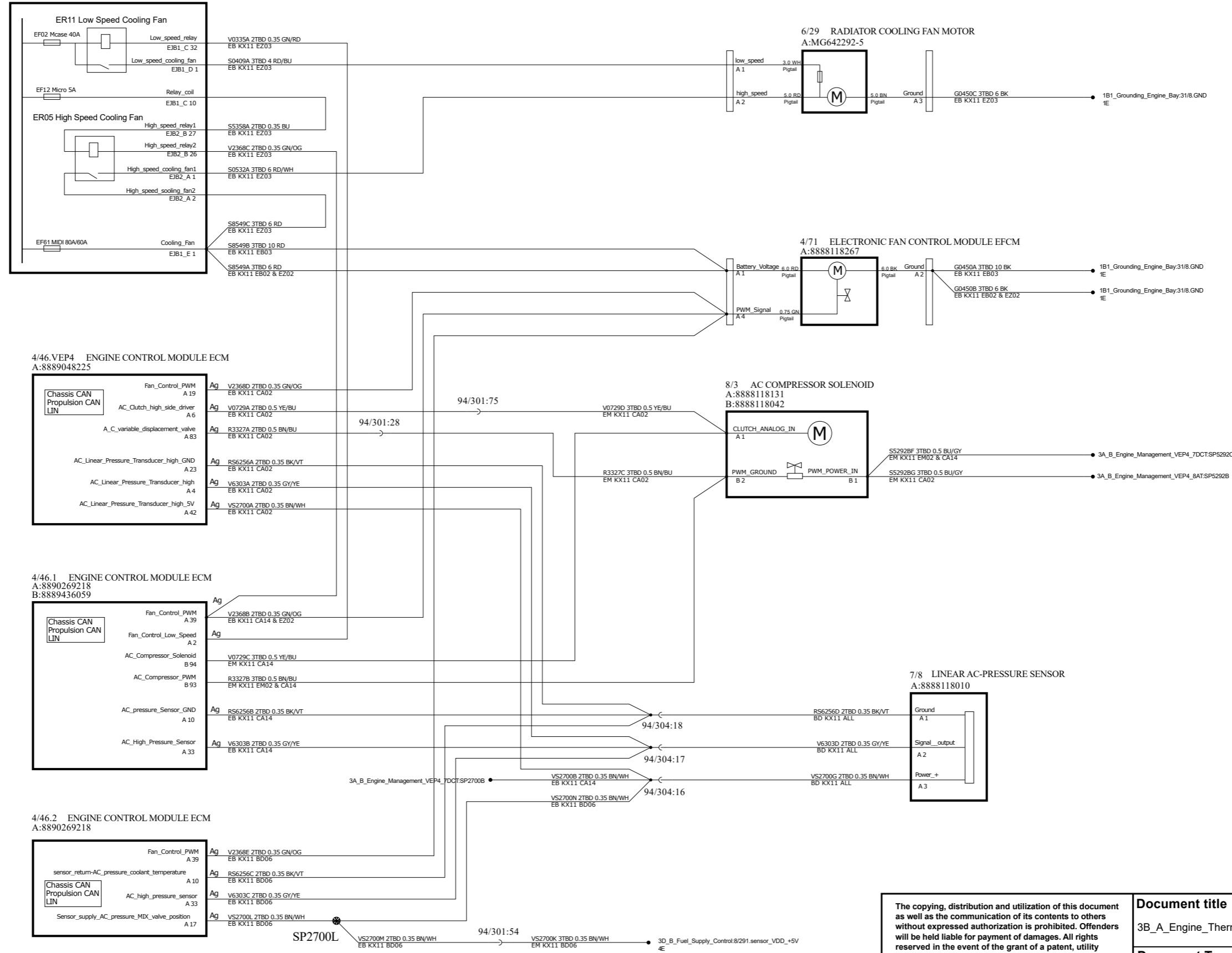

The copying, distribution and utilization of this document as well as the communication of its contents to others without expressed authorization is prohibited. Offenders will be held liable for payment of damages. All rights reserved in the event of the grant of a patent, utility model or ornamental design registration.

Document title		KX11_MP1_base_B7	
3B_A_Engine_Thermal_Management			
Document Type	DRAW/ELSY	Release Status	Released
Document No	8889755035	Edited	September/18/2021
Issue	007	Page No	46/83

GEELY

3B Engine Thermal Management

15/44 HYBRID MAIN DISTRIBUTION BOX 1
H:K031442D-6-8

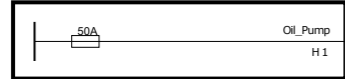

6/179 TRANSMISSION ELECTRICAL OIL PUMP
A:8891087032



15/49 ENGINE JUNCTION BOX
EJB1_B:8889434927
EJB1_C:888964514

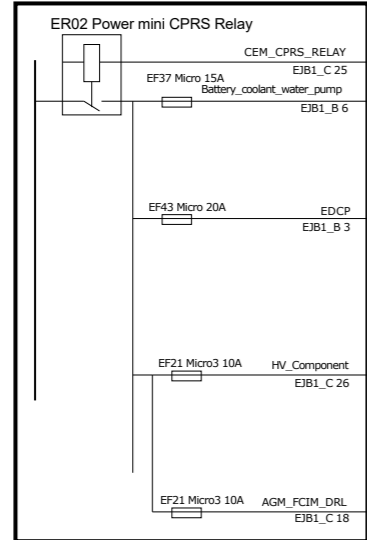

6/195 BATTERY COOLANT WATER PUMP 1
A:8889645114



4/178 ELECTRIC DRIVETRAIN COOLANT PUMP EDCP
A:888957765



4/134 CONTROL UNIT PROPORTIONAL COOLING WATER VALVE PWV
A:8889645114



6/184 ELECTRIC AC COMPRESSOR
LV:8889741090



8/185 HVAC COOLING SHUT OFF VALVE
A:1-967644-1

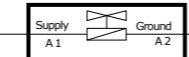

8/186 CHILLER SHUT OFF VALVE
A:1-967644-1

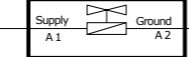

7/16.2 COOLANT TEMPERATURE SENSOR
A:2-1670916-1



4/46.2 ENGINE CONTROL MODULE ECM
A:8890269218
B:8889436059

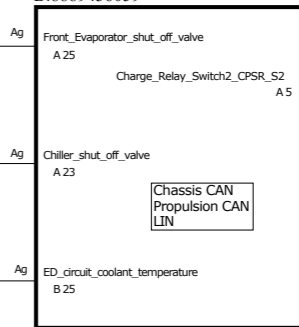

SP8535A

SP8535C

SP8534A

SP8534D

The copying, distribution and utilization of this document as well as the communication of its contents to others without expressed authorization is prohibited. Offenders will be held liable for payment of damages. All rights reserved in the event of the grant of a patent, utility model or ornamental design registration.

GEELY

Document title KX11_MP1_base_B7 3B_B_Engine_Thermal_Management	
Document Type DRAW/ELSY	Release Status Released
Document No 8889755035	Edited October/19/2021
Issue 007	Page No 47/83

3C Transmission 7DCT

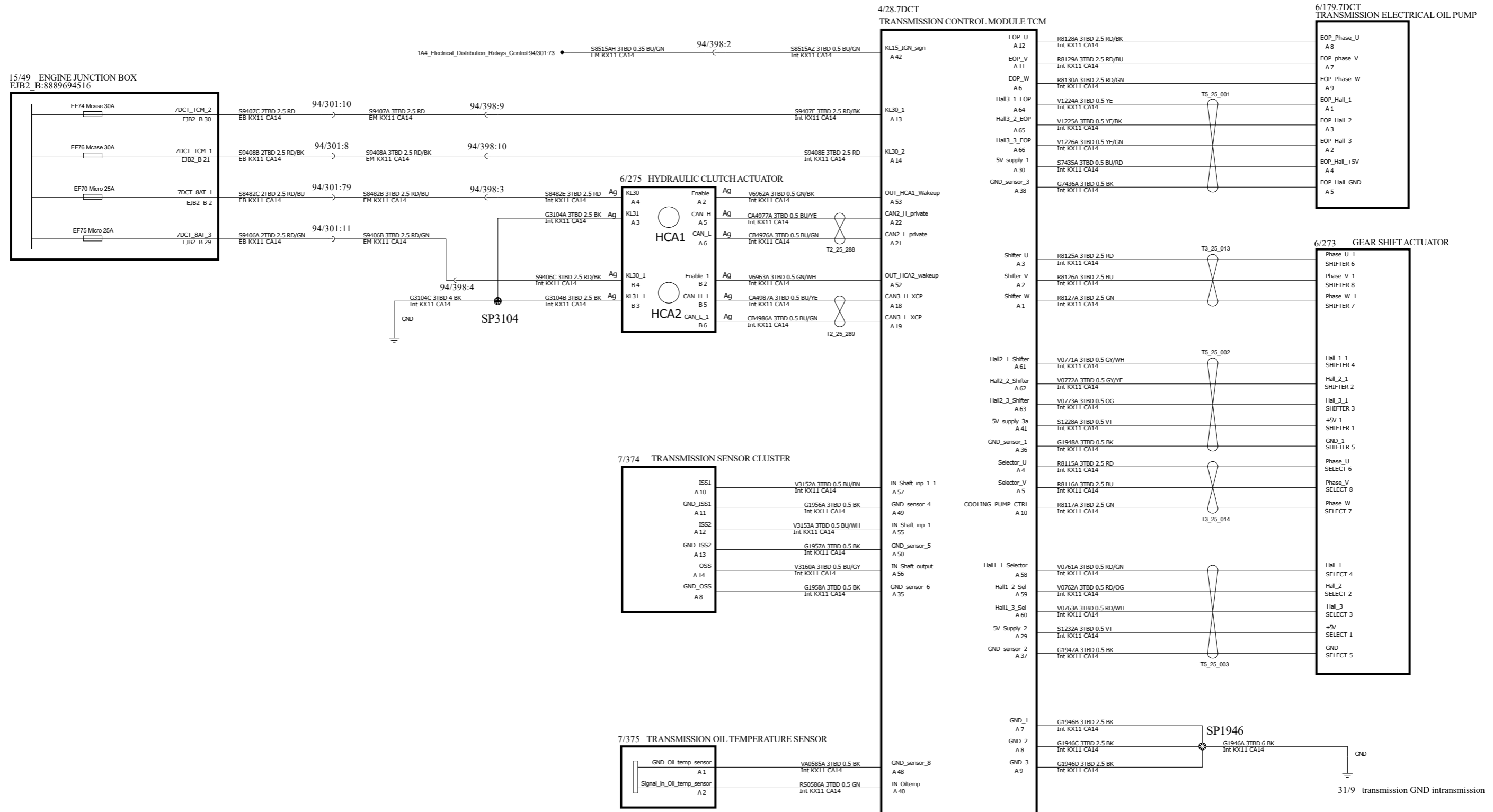

<p>The copying, distribution and utilization of this document as well as the communication of its contents to others without expressed authorization is prohibited. Offenders will be held liable for payment of damages. All rights reserved in the event of the grant of a patent, utility model or ornamental design registration.</p>		<p>Document title KX11_MP1_base_B7</p>	
		<p>3C_Transmission_7DCT</p>	
<p>Document Type DRAW/ELSY</p>		<p>Release Status Released</p>	
<p>Document No 8889755035</p>		<p>Edited October/19/2021</p>	
<p>Issue 007</p>		<p>Page No 48/83</p>	

GEELY

3C Transmission 8AT

15/49 ENGINE JUNCTION BOX
EJB2 B:8889694516

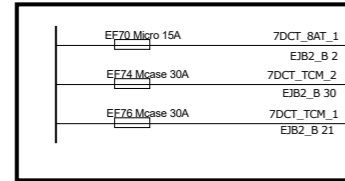

4/46 VEP4 ENGINE CONTROL MODULE ECM
A:8889048225

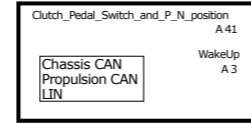

4/56 CENTRAL ELECTRONIC MODULE CEM
ENG:8888116317



4/28.8AT TRANSMISSION CONTROL MODULE TCM
A:8888860622

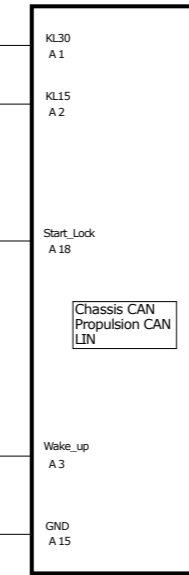

4/209 TRANSMISSION ACTUATOR CONTROL MODULE TACM
A:8889623993

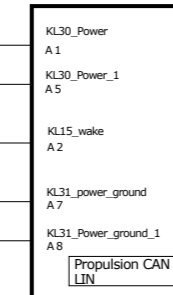

4/82 DIFFERENTIAL ELECTRONIC MODULE DEM
A:8888118277

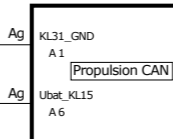

4/197 ELECTRONIC GEAR SELECTOR MODULE EGSM
Y:8888116273

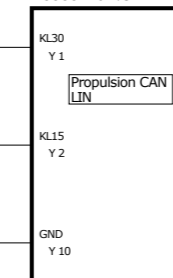

15/50 CENTRAL JUNCTION BOX
A:8889098582

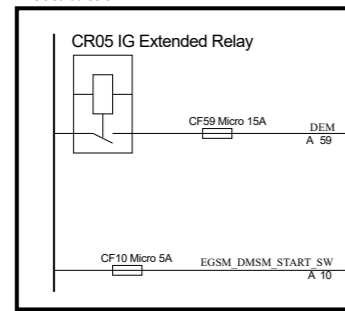

4/283 DRIVE MODE SWITCH MODULE DMSM
A:8889627685

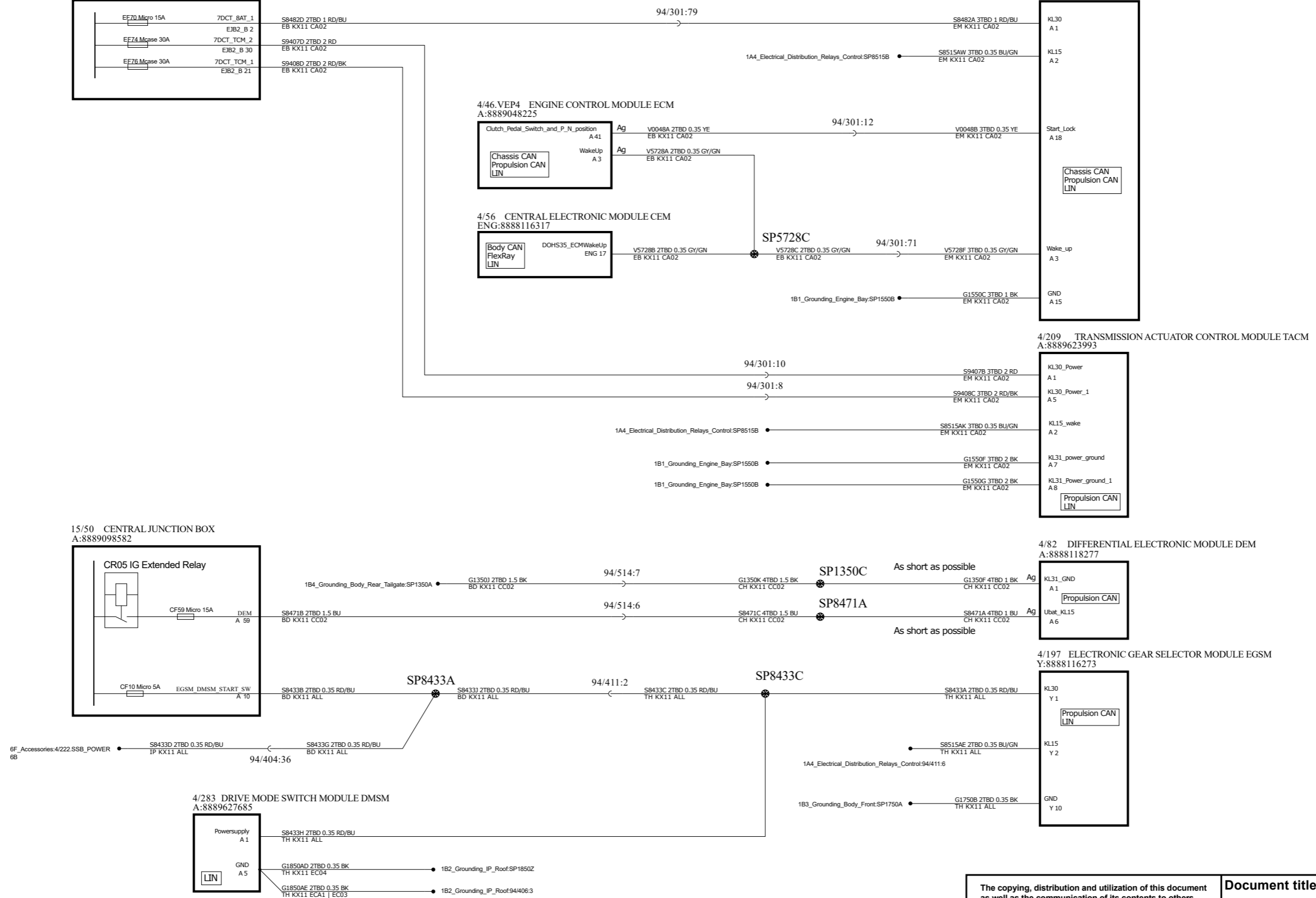
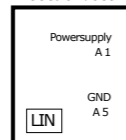

<p>The copying, distribution and utilization of this document as well as the communication of its contents to others without expressed authorization is prohibited. Offenders will be held liable for payment of damages. All rights reserved in the event of the grant of a patent, utility model or ornamental design registration.</p> <h2 style="margin: 0;">GEELY</h2>	<p>Document title KX11_MP1_base_B7 3C_Transmission_8AT</p>	
	<p>Document Type DRAW/ELSY</p>	<p>Release Status Released</p>
	<p>Document No 8889755035</p>	<p>Edited May/14/2021</p>
	<p>Issue 007</p>	<p>Page No 49/83</p>

3D Fuel Supply Control

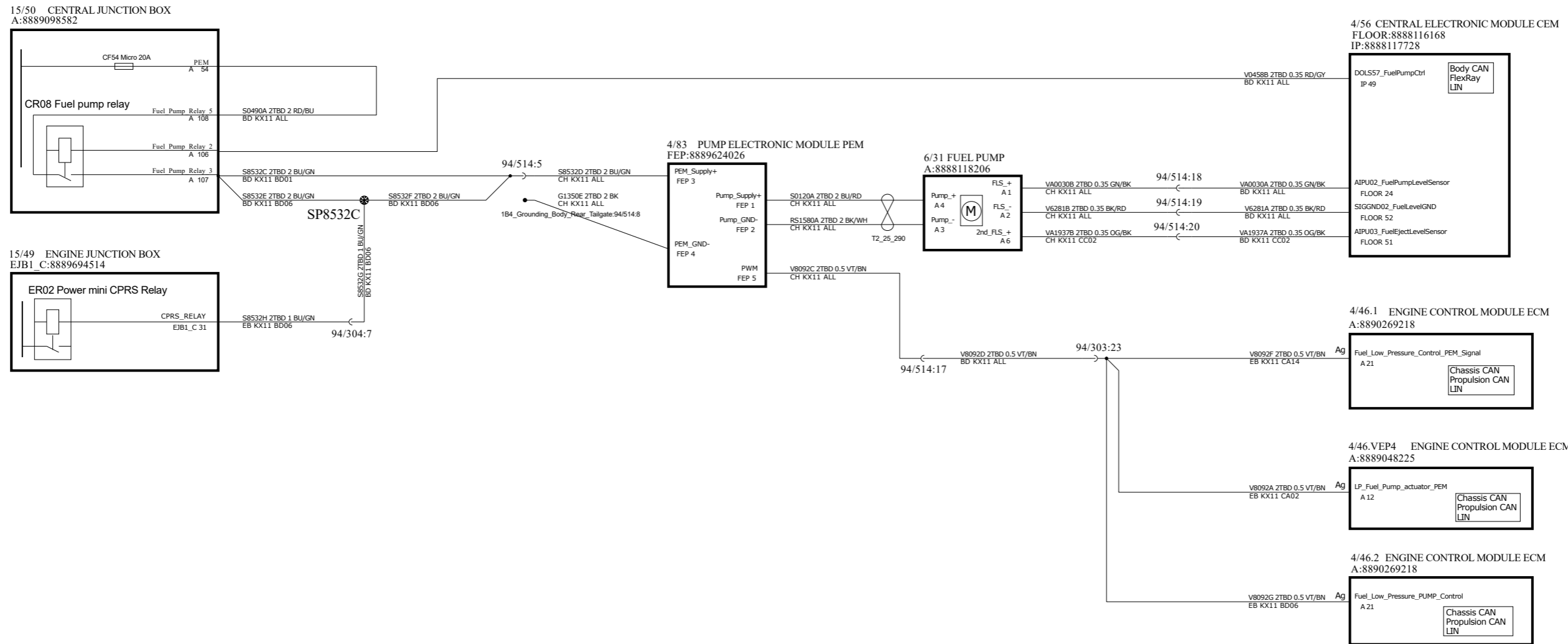

<p>The copying, distribution and utilization of this document as well as the communication of its contents to others without expressed authorization is prohibited. Offenders will be held liable for payment of damages. All rights reserved in the event of the grant of a patent, utility model or ornamental design registration.</p> <p style="text-align: center;">GEELY</p>	Document title KX11_MP1_base_B7 3D_A_Fuel_Supply_Control	
	Document Type DRAW/ELSY	Release Status Released
	Document No 8889755035	Edited December/28/2020
	Issue 007	Page No 50/83

3D Fuel Supply Control

4/46 VEP4 ENGINE CONTROL MODULE ECM
A:8889048225
B:8889048223

8/18 EVAP PURGE VALVE
A:8888119605

6/202 LEAKAGE DETECTION PUMP
A:8888118392

SP5292E

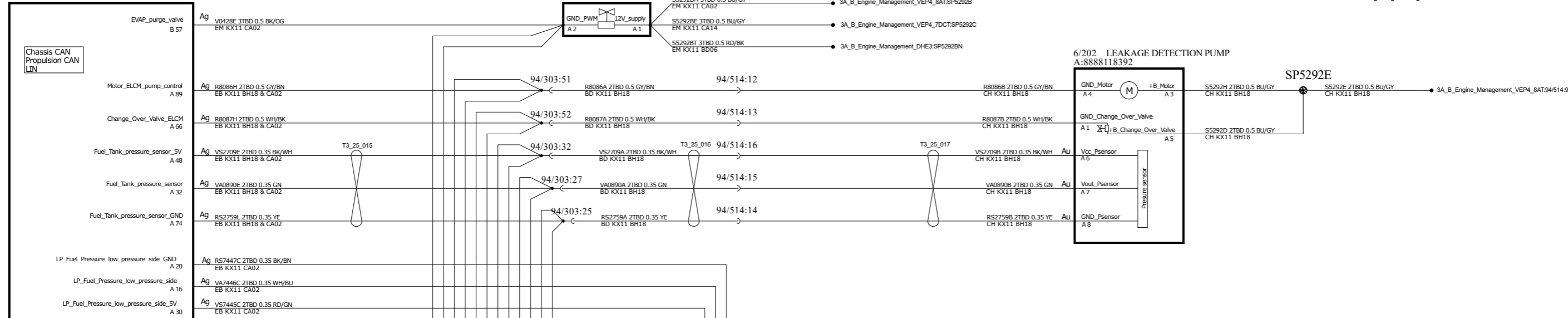

4/46.1 ENGINE CONTROL MODULE ECM
A:8890269218

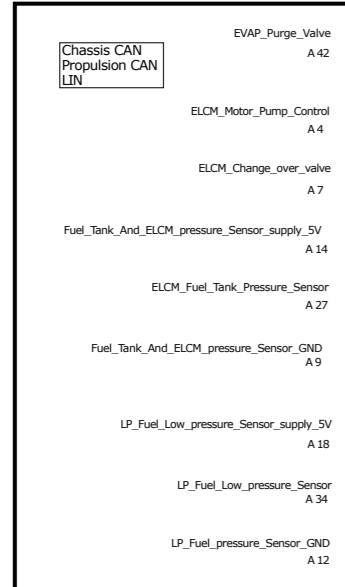

7/140 FUEL PRESSURE SENSOR ENGINE
A:8888118113

4/46.2 ENGINE CONTROL MODULE ECM
A:8890269218

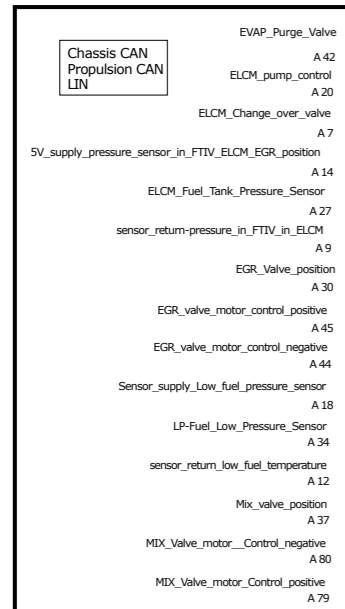

8/120 ELECTRONIC EGR VALVE
A:1928404900

8/291 DELTA PRESSURE EGR VALVE
A:1438153-8

The copying, distribution and utilization of this document as well as the communication of its contents to others without expressed authorization is prohibited. Offenders will be held liable for payment of damages. All rights reserved in the event of the grant of a patent, utility model or ornamental design registration.

GEELY

Document title KX11_MP1_base_B7	
3D_B_Fuel_Supply_Control	
Document Type DRAW/ELSY	Release Status Released
Document No 8889755035	Edited October/19/2021
Issue 007	Page No 51/83

4A Parking Assistance

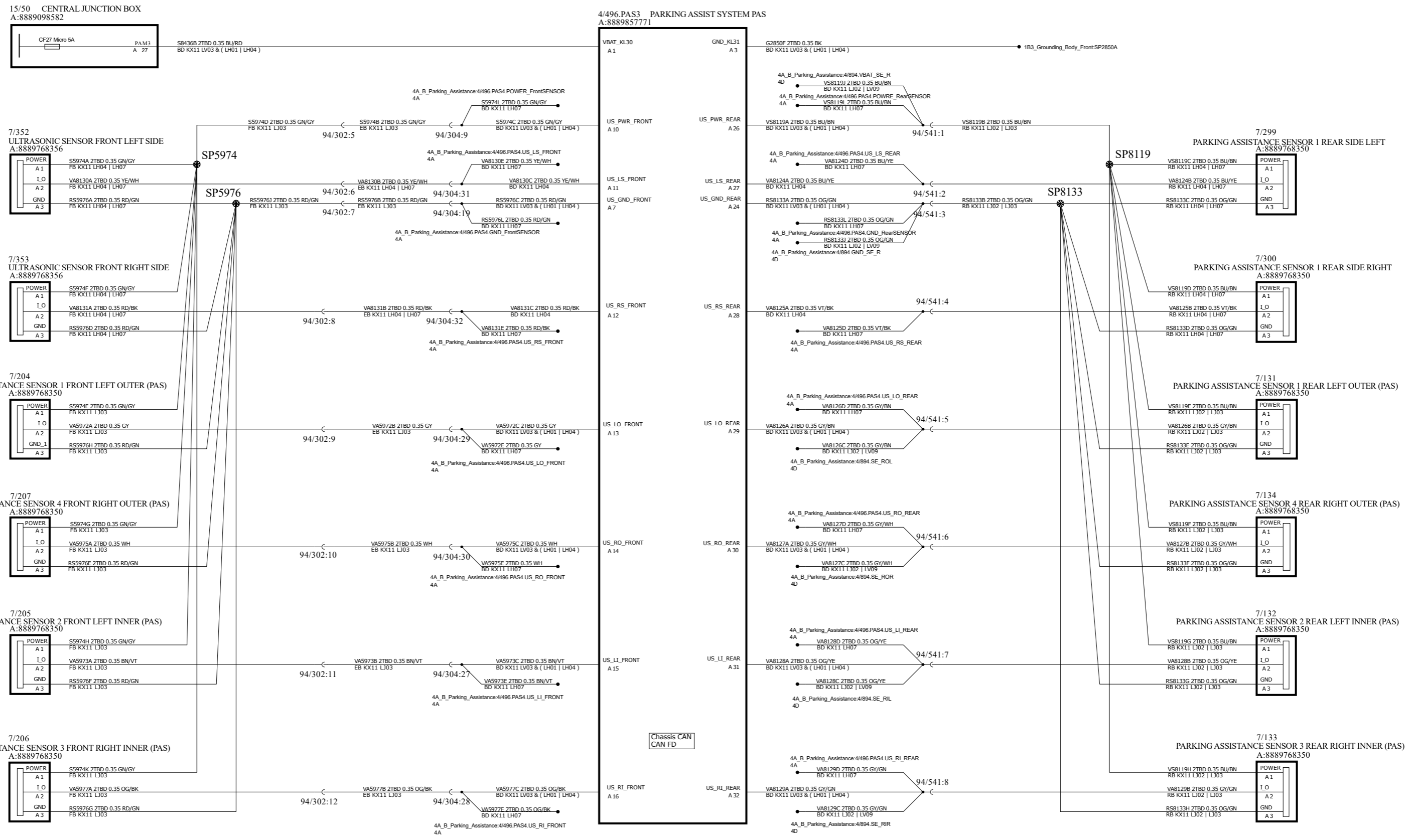

<p>The copying, distribution and utilization of this document as well as the communication of its contents to others without expressed authorization is prohibited. Offenders will be held liable for payment of damages. All rights reserved in the event of the grant of a patent, utility model or ornamental design registration.</p>		<p>Document title KX11_MP1_base_B7</p>	
		<p>4A_A_Parking_Assistance</p>	
<p>Document Type DRAW/ELSY</p>		<p>Release Status Released</p>	
<p>Document No 8889755035</p>		<p>Edited April/16/2021</p>	
<p>Issue 007</p>		<p>Page No 52/83</p>	

GEELY

4A Parking Assistance

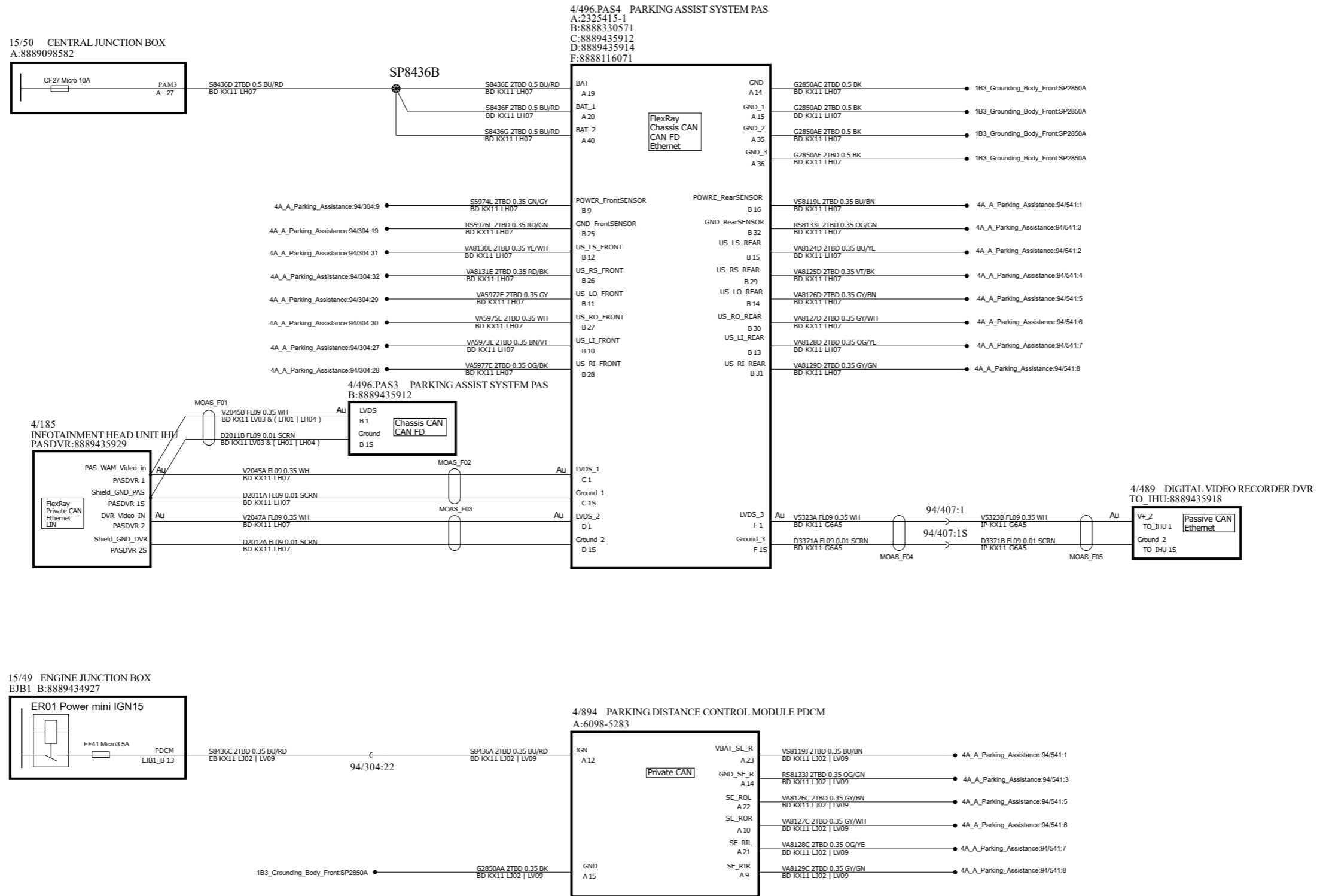

<p>The copying, distribution and utilization of this document as well as the communication of its contents to others without expressed authorization is prohibited. Offenders will be held liable for payment of damages. All rights reserved in the event of the grant of a patent, utility model or ornamental design registration.</p> <h2 style="margin: 0;">GEELY</h2>	Document title KX11_MP1_base_B7	
	4A_B_Parking_Assistance	
	Document Type DRAW/ELSY	Release Status Released
	Document No 8889755035	Edited September/27/2021
Issue 007	Page No 53/83	

4B Visual Assistance

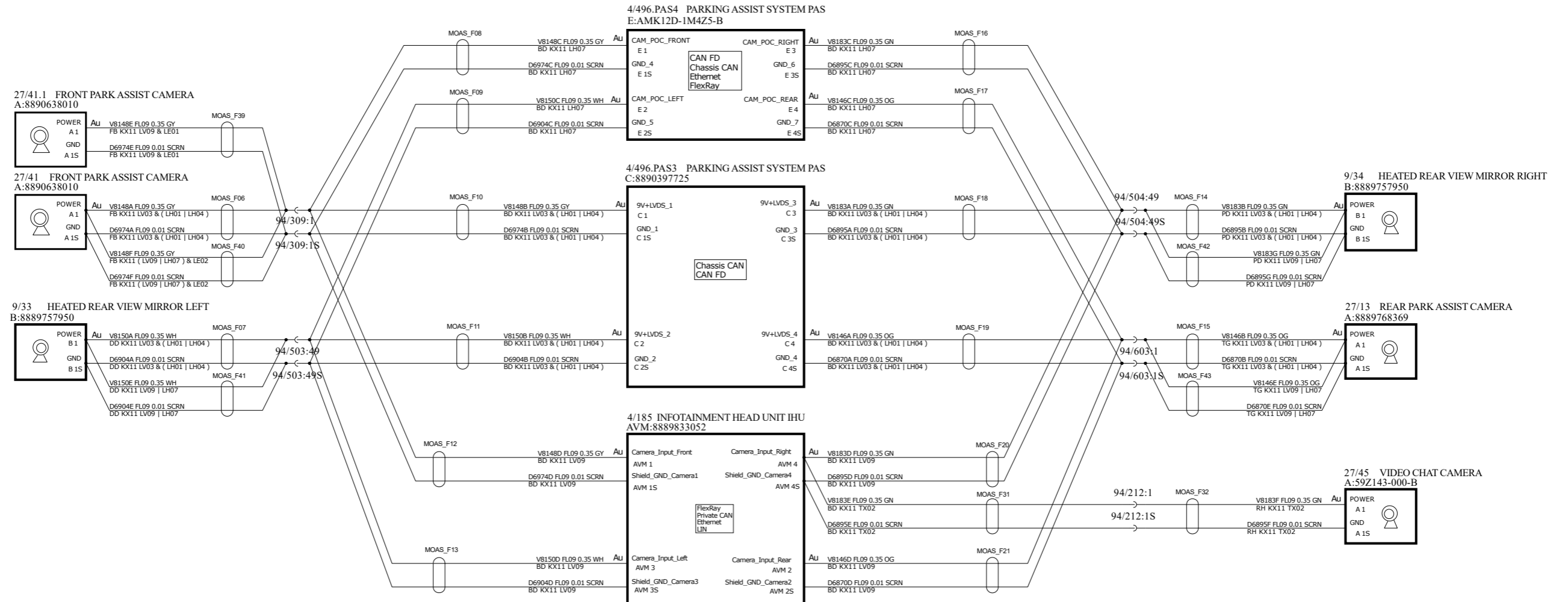

GEELY	Document title KX11_MP1_base_B7 4B_Visual_Assistance	
	Document Type DRAW/ELSY	Release Status Released
	Document No 8889755035	Edited May/24/2021
	Issue 007	Page No 54/83

4C Keyless Vehicle Antenna

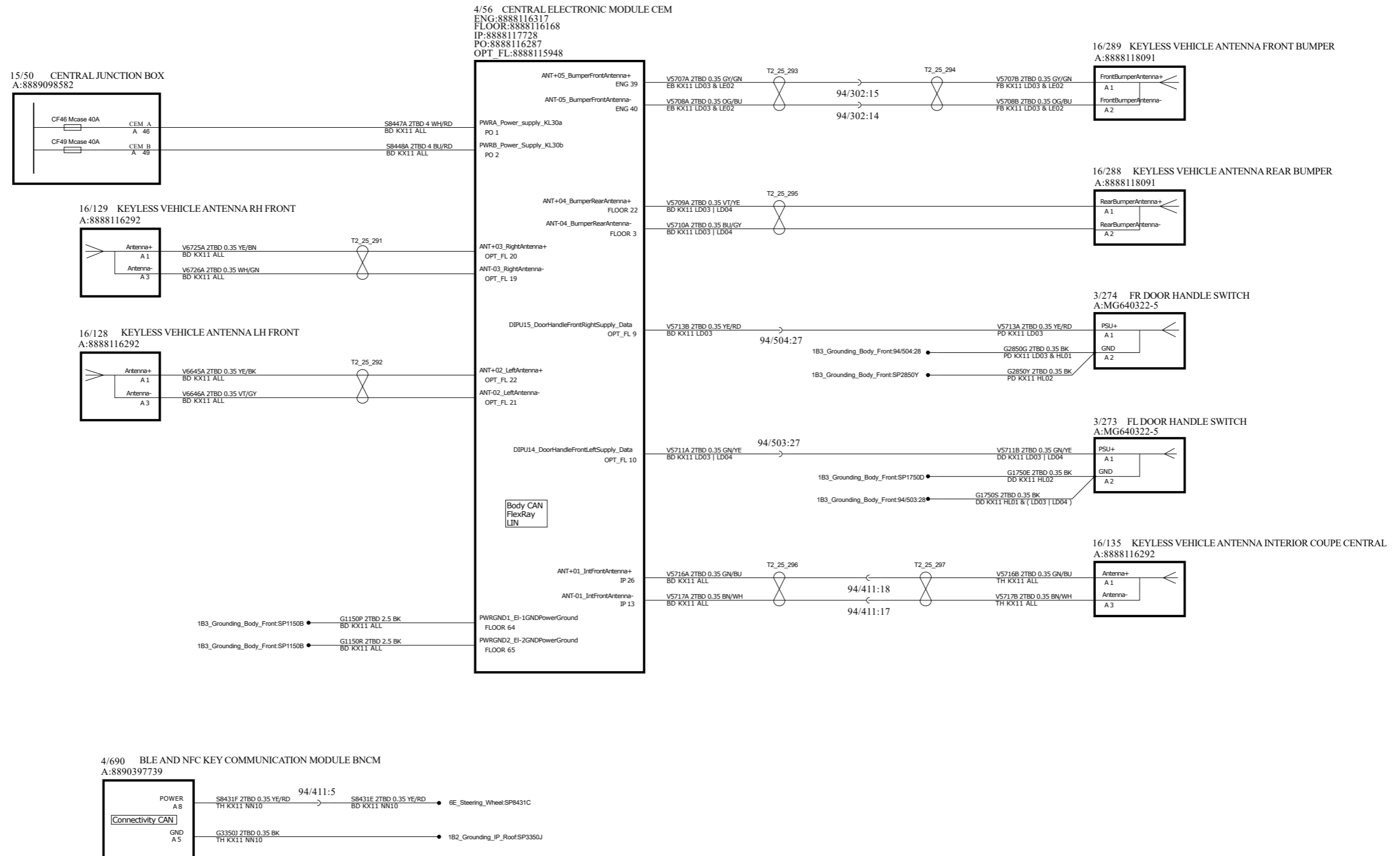

<p>The copying, distribution and utilization of this document as well as the communication of its contents to others without expressed authorization is prohibited. Offenders will be held liable for payment of damages. All rights reserved in the event of the grant of a patent, utility model or ornamental design registration.</p>		<p>Document title KX11_MP1_base_B7</p>	
		<p>4C_Keyless_Vehicle_Antenna</p>	
<p>Document Type DRAW/ELSY</p>		<p>Release Status Released</p>	
<p>Document No 8889755035</p>		<p>Edited March/25/2021</p>	
<p>Issue 007</p>		<p>Page No 55/83</p>	

GEELY

5A Climate Control

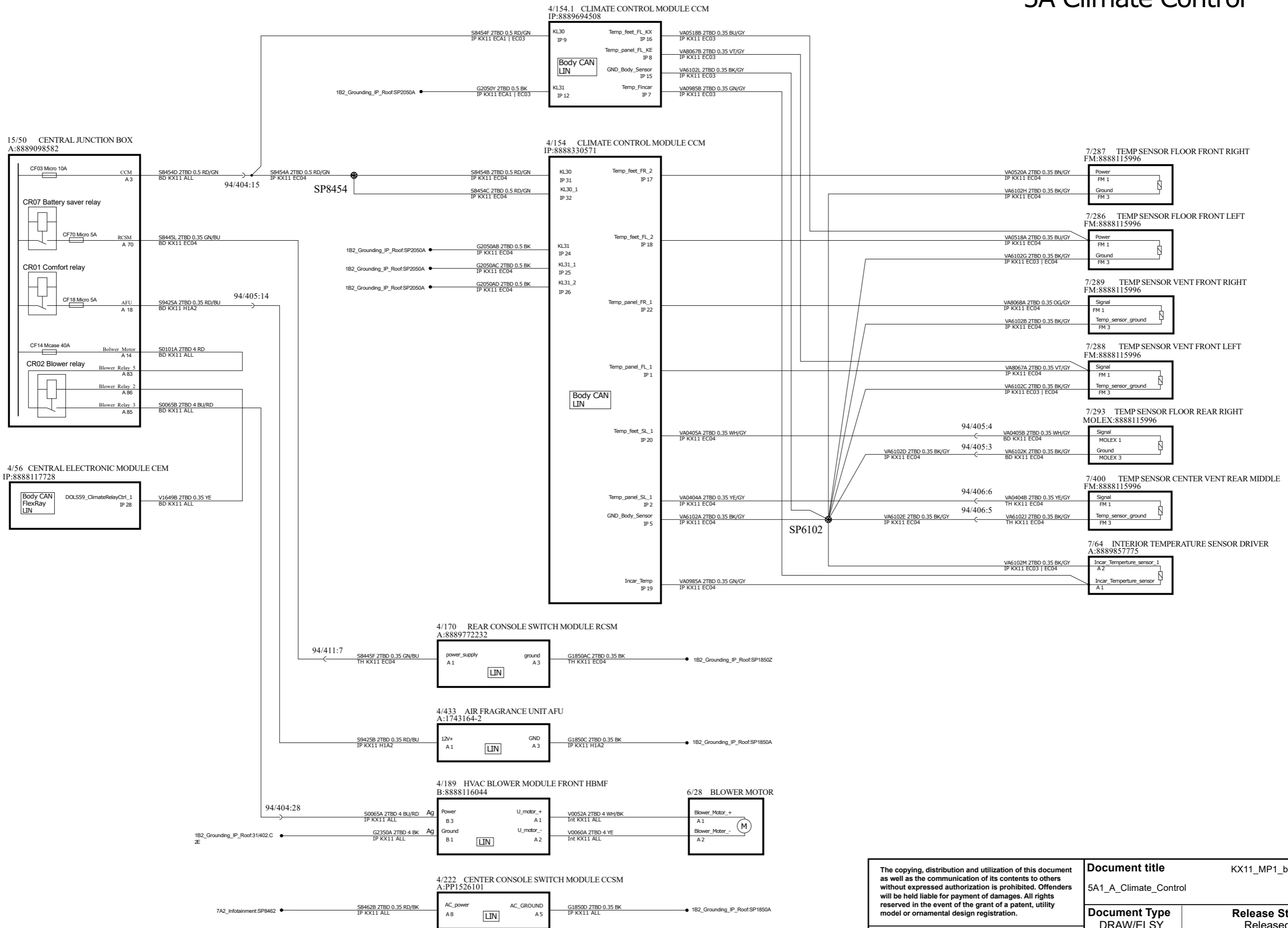

The copying, distribution and utilization of this document as well as the communication of its contents to others without expressed authorization is prohibited. Offenders will be held liable for payment of damages. All rights reserved in the event of the grant of a patent, utility model or ornamental design registration.

GEELY

Document title		KX11_MP1_base_B7	
5A1_A_Climate_Control			
Document Type	DRAW/ELSY	Release Status	Released
Document No	8889755035	Edited	September/22/2021
Issue	007	Page No	56/83

5A Climate Control Internal

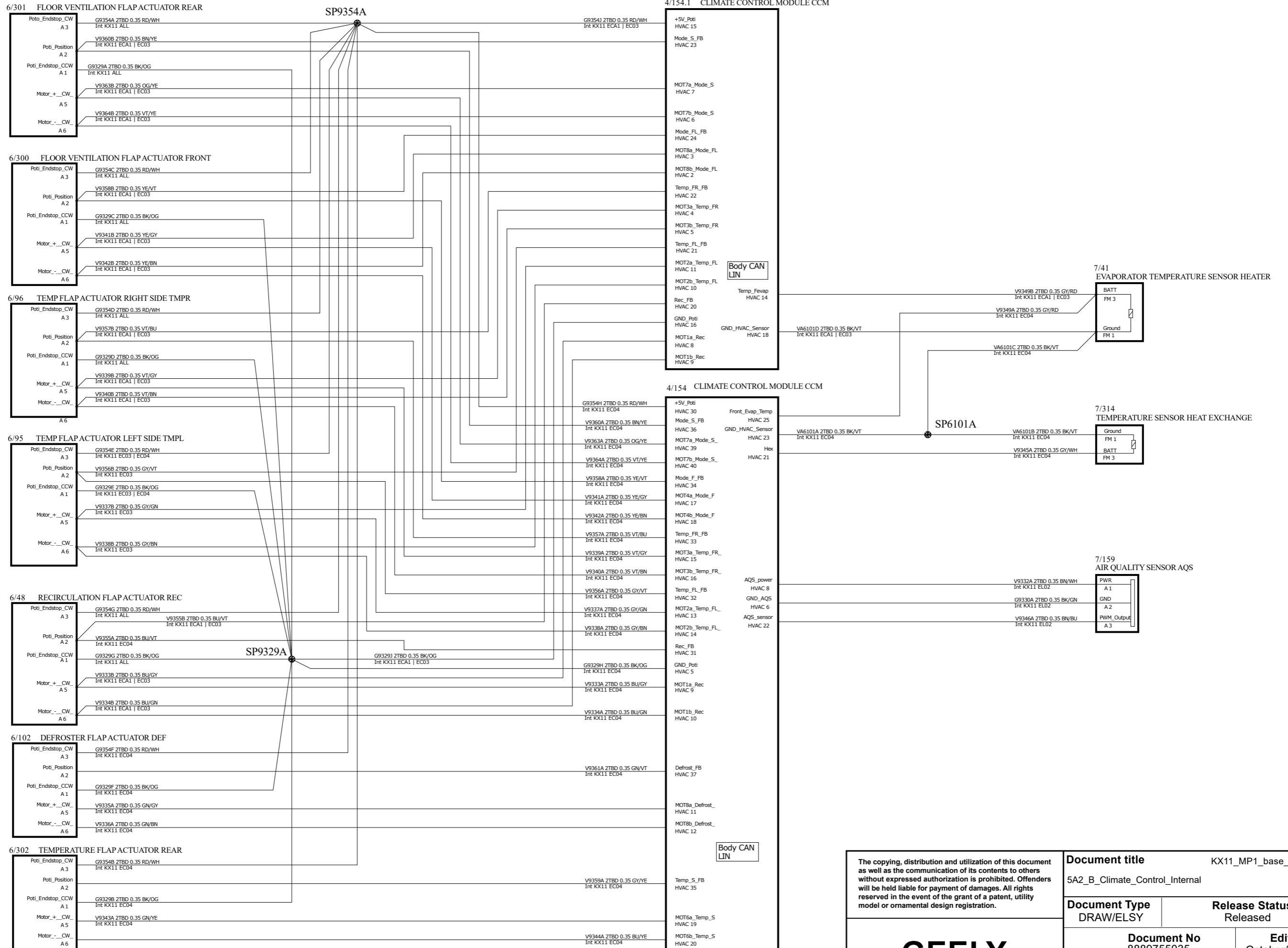

	Document title KX11_MP1_base_B7 5A2_B_Climate_Control_Internal	
	Document Type DRAW/ELSY	Release Status Released
	Document No 8889755035	Edited October/19/2021
	Issue 007	Page No 57/83

The copying, distribution and utilization of this document as well as the communication of its contents to others without expressed authorization is prohibited. Offenders will be held liable for payment of damages. All rights reserved in the event of the grant of a patent, utility model or ornamental design registration.

5B1 Power Seat

15/50 CENTRAL JUNCTION BOX
A:8889098582

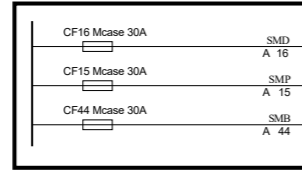

22/3 DRIVER SEAT CONNECTION
A:8888117720

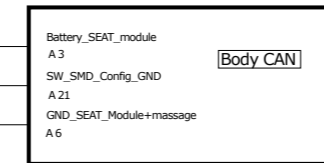

22/4 PASSENGER SEAT CONNECTION
A:8888117720



4/428 SEAT MODULE BACK SMB
A:8889234783
B:8889234787

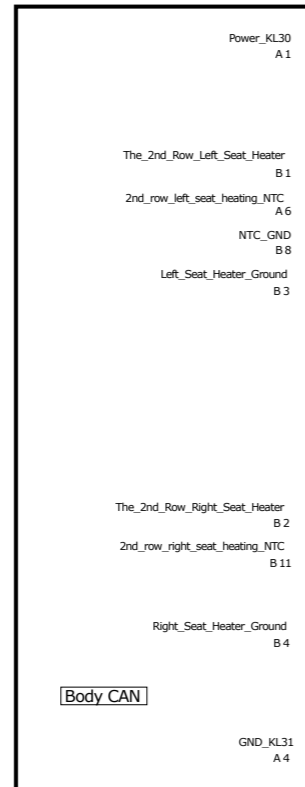

94/522 INLINE CUSHION BACKREST 2nd ROW LEFT
A:8889645256
B:8888116367

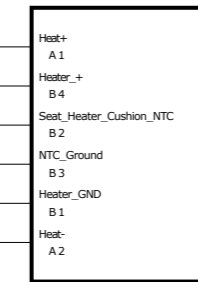

94/523 INLINE CUSHION BACKREST 2nd ROW RIGHT
A:8889645256
B:8888116367

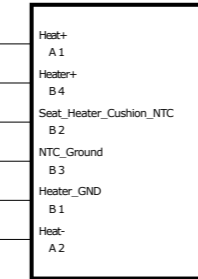

The copying, distribution and utilization of this document as well as the communication of its contents to others without expressed authorization is prohibited. Offenders will be held liable for payment of damages. All rights reserved in the event of the grant of a patent, utility model or ornamental design registration.

GEELY

Document title 5B1_Power_Seat		KX11_MP1_base_B7	
Document Type DRAW/ELSY	Release Status Released		
Document No 8889755035		Edited December/15/2020	
Issue 007		Page No 58/83	

5B2 Power Seat Driver Internal High

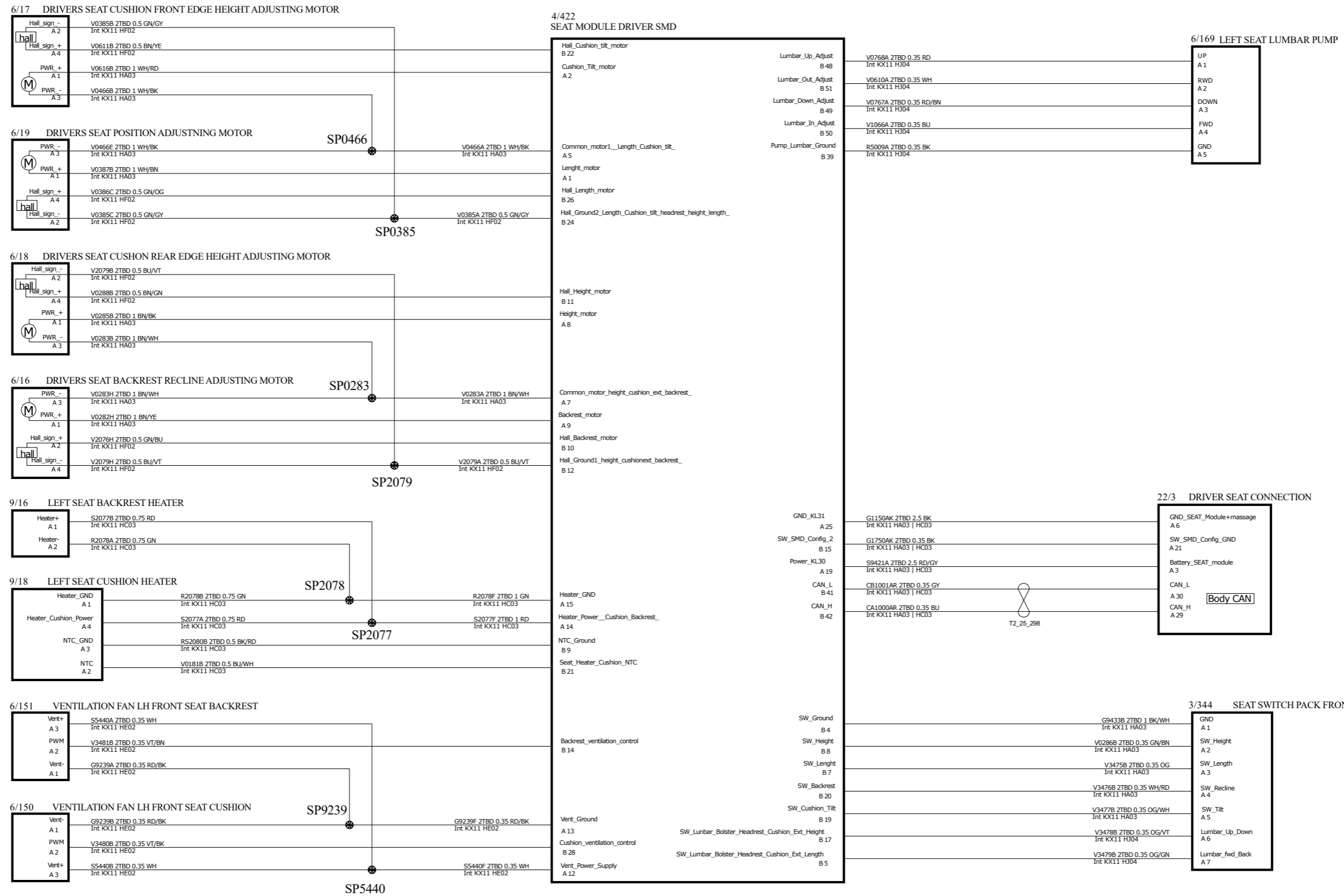

<p>The copying, distribution and utilization of this document as well as the communication of its contents to others without expressed authorization is prohibited. Offenders will be held liable for payment of damages. All rights reserved in the event of the grant of a patent, utility model or ornamental design registration.</p> <h2 style="margin: 0;">GEELY</h2>	<p>Document title KX11_MP1_base_B7 5B2_A_Power_Seat_Driver_Internal</p>	
	<p>Document Type DRAW/ELSY</p>	<p>Release Status Released</p>
	<p>Document No 8889755035</p>	<p>Edited December/04/2020</p>
	<p>Issue 007</p>	<p>Page No 59/83</p>

5B2 Power Seat Driver Internal Low

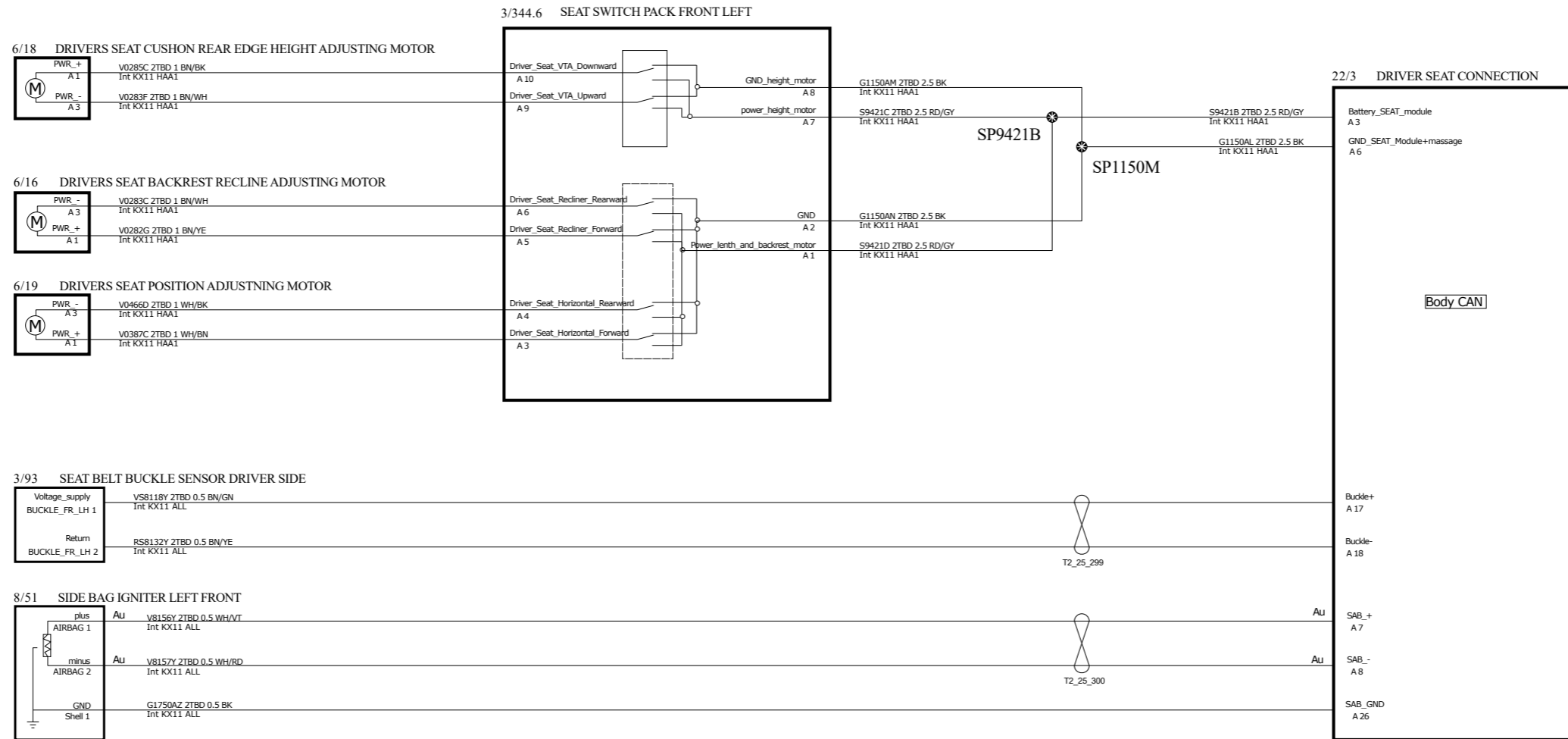

GEELY	Document title KX11_MP1_base_B7 5B2_B_Power_Seat_Driver_Internal	
	Document Type DRAW/ELSY	Release Status Released
	Document No 8889755035	Edited December/04/2020
	Issue 007	Page No 60/83

5B3 Power Seat Passenger Internal

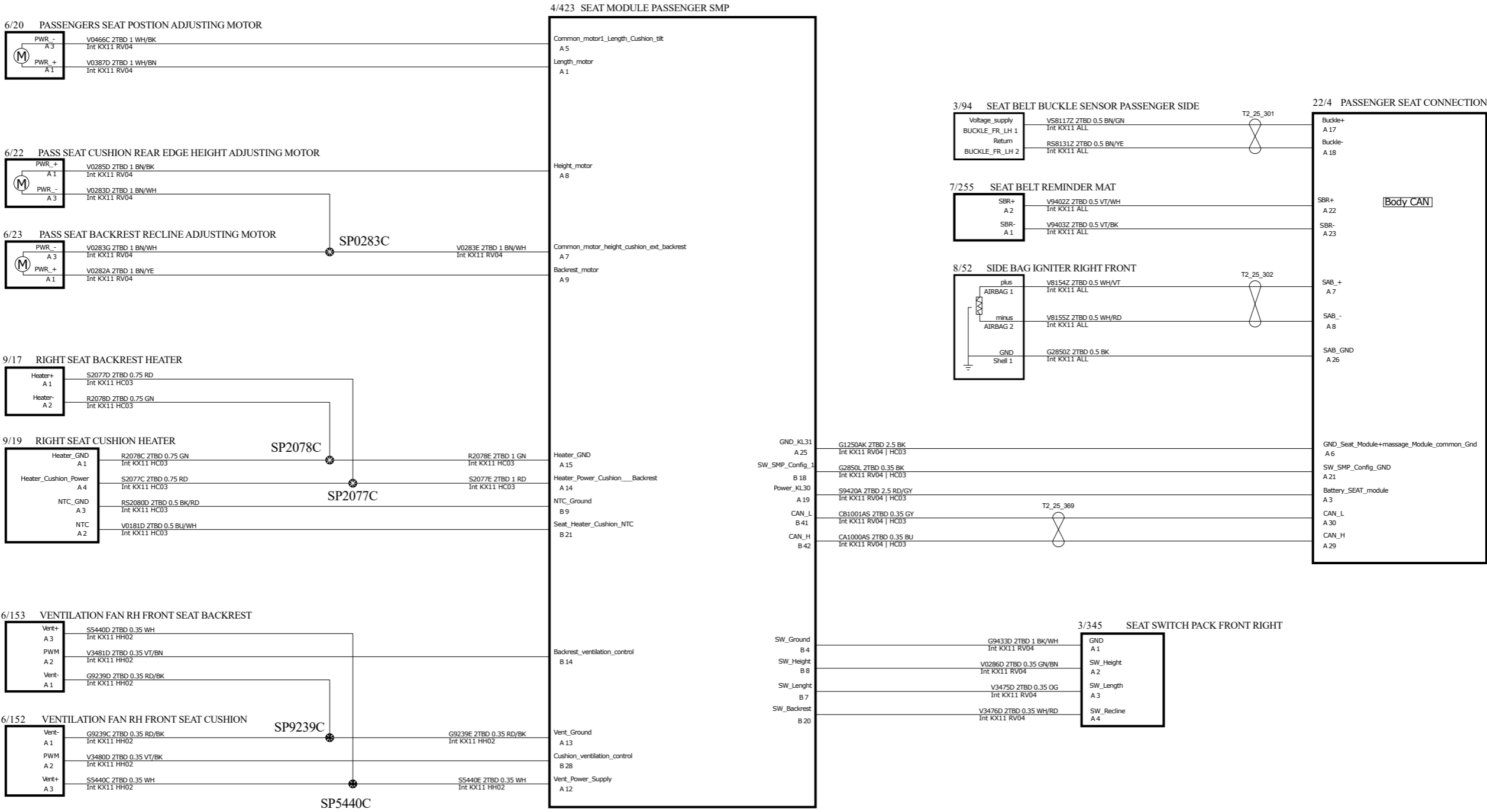

<p>The copying, distribution and utilization of this document as well as the communication of its contents to others without expressed authorization is prohibited. Offenders will be held liable for payment of damages. All rights reserved in the event of the grant of a patent, utility model or ornamental design registration.</p> <p style="text-align: center;">GEELY</p>	Document title KX11_MP1_base_B7 5B3_Power_Seat_Passenger_Internal	
	Document Type DRAW/ELSY	Release Status Released
	Document No 8889755035	Edited December/04/2020
	Issue 007	Page No 61/83

6A1 Power Door Driver

4/468 DRIVER DOOR MODULE DDM
 A:8888116353
 B:8888116391
 C:8889070797

15/50 CENTRAL JUNCTION BOX
 A:8889098582

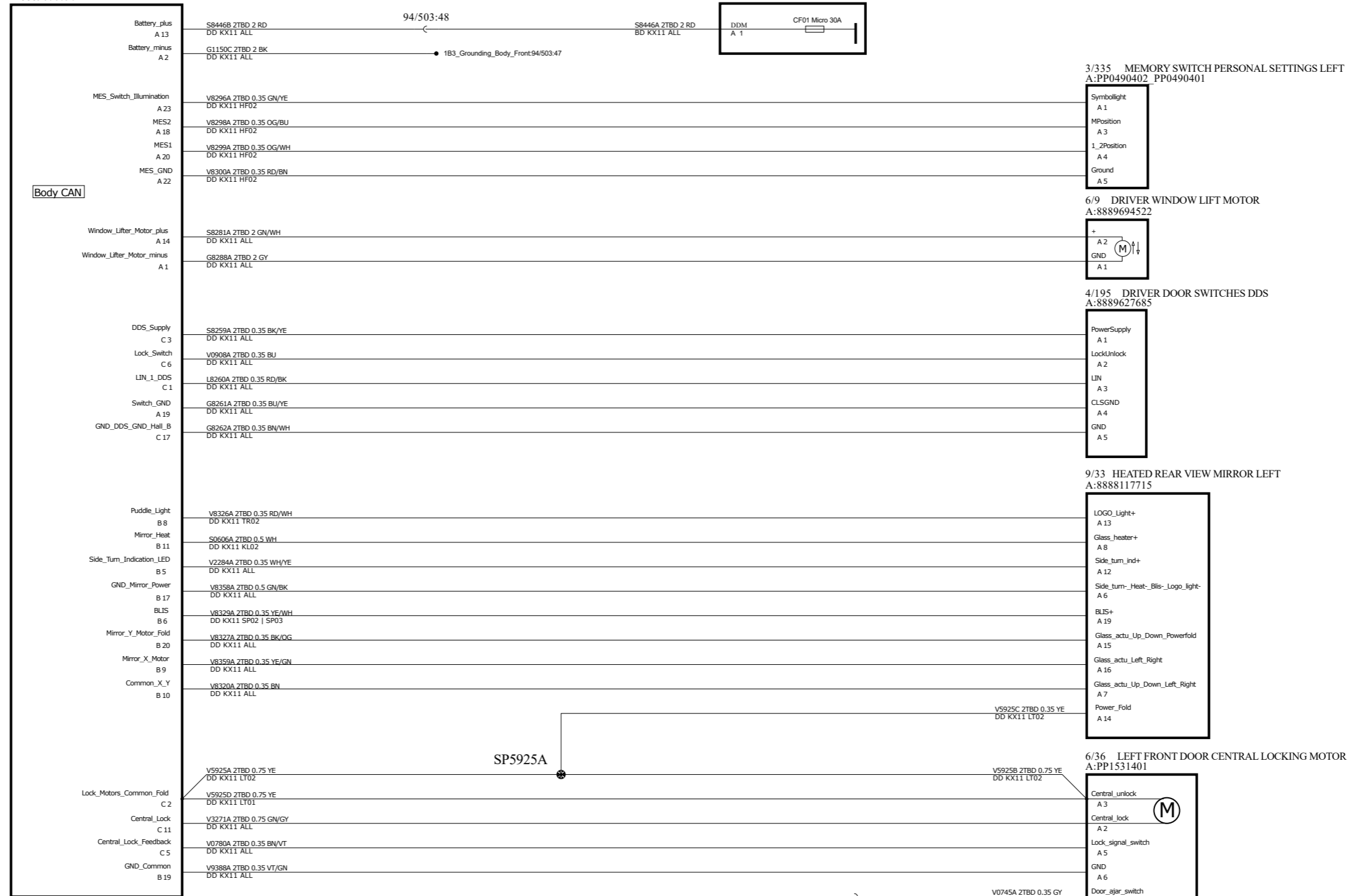

4/56 CENTRAL ELECTRONIC MODULE CEM
 FLOOR:8888116168



<p>The copying, distribution and utilization of this document as well as the communication of its contents to others without expressed authorization is prohibited. Offenders will be held liable for payment of damages. All rights reserved in the event of the grant of a patent, utility model or ornamental design registration.</p> <p style="text-align: center;">GEELY</p>	<p>Document title KX11_MP1_base_B7</p> <p>6A1_Power_Door_Driver</p>	
	<p>Document Type DRAW/ELSY</p>	<p>Release Status Released</p>
	<p>Document No 8889755035</p>	<p>Edited October/19/2021</p>
	<p>Issue 007</p>	<p>Page No 62/83</p>

6A2 Power Door Passenger

4/469 PASSENGER DOOR MODULE PDM
 A:8888116353
 B:8888116391
 C:8889070797

15/50 CENTRAL JUNCTION BOX
 A:8889098582

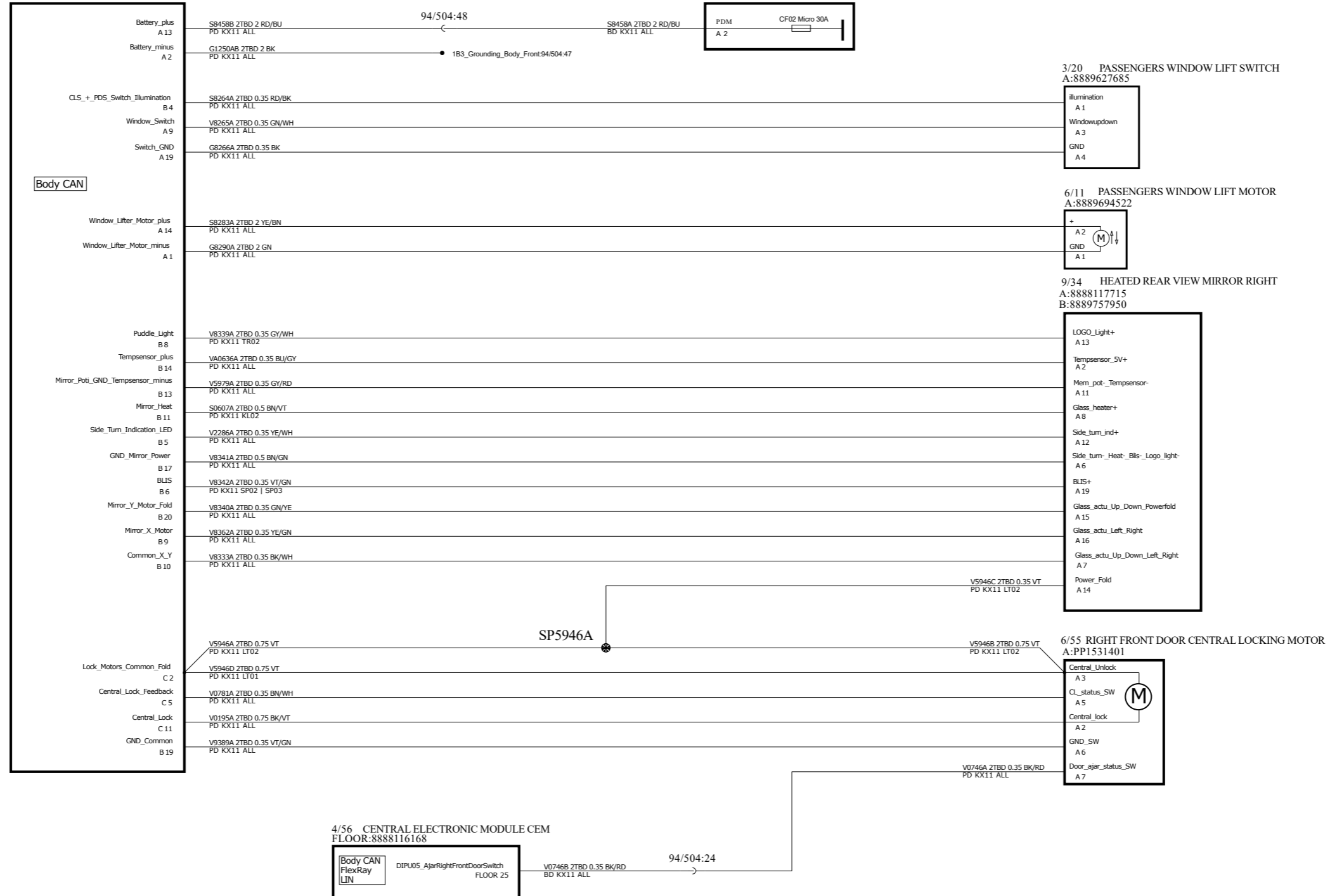

<p>The copying, distribution and utilization of this document as well as the communication of its contents to others without expressed authorization is prohibited. Offenders will be held liable for payment of damages. All rights reserved in the event of the grant of a patent, utility model or ornamental design registration.</p> <p style="text-align: center;">GEELY</p>	Document title KX11_MP1_base_B7 6A2_Power_Door_Passenger	
	Document Type DRAW/ELSY	Release Status Released
	Document No 8889755035	Edited October/19/2021
	Issue 007	Page No 63/83

6A3 Power Door Rear Left

4/539 REAR LEFT DOOR MODULE RLDM
 A:8888116353
 B:8888116391

15/50 CENTRAL JUNCTION BOX
 A:8889098582

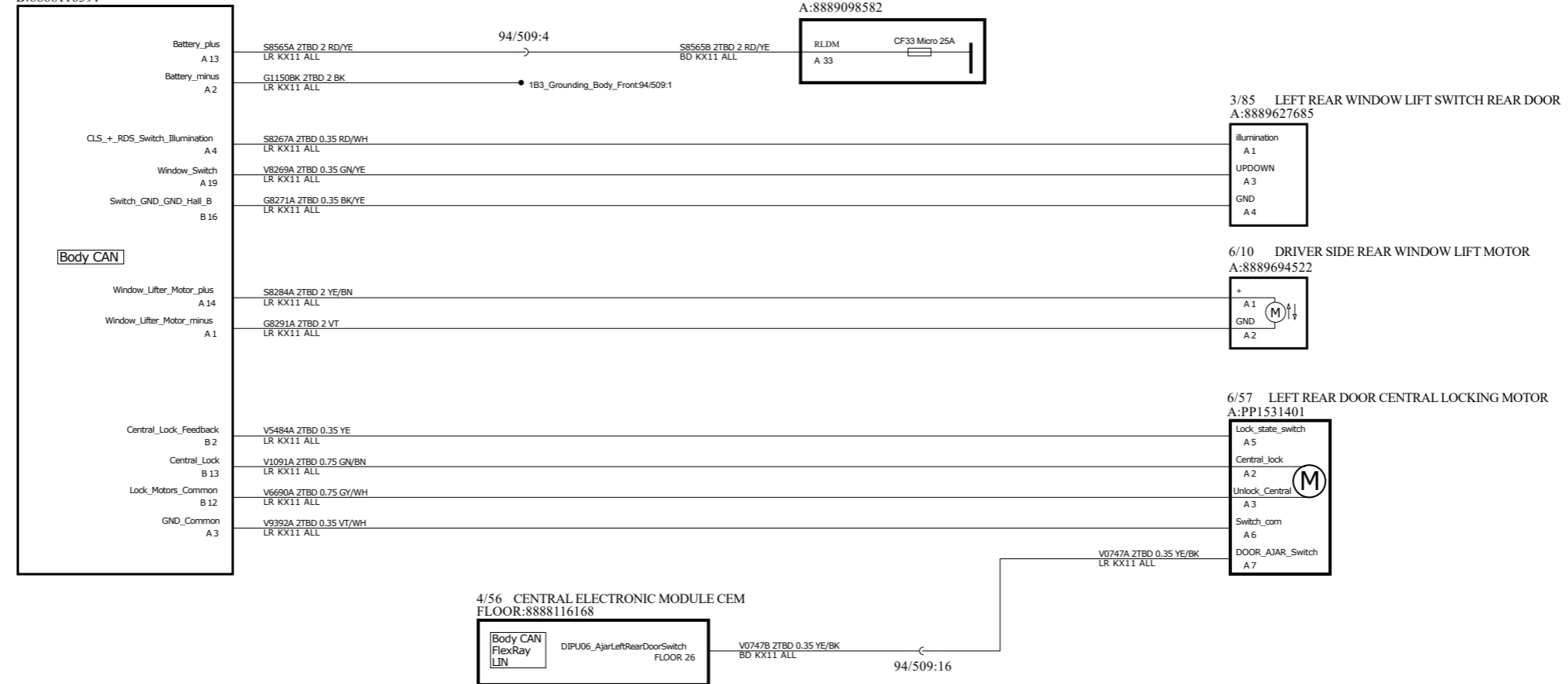

<p>The copying, distribution and utilization of this document as well as the communication of its contents to others without expressed authorization is prohibited. Offenders will be held liable for payment of damages. All rights reserved in the event of the grant of a patent, utility model or ornamental design registration.</p> <p style="text-align: center;">GEELY</p>	Document title KX11_MP1_base_B7 6A3_Power_Door_Rear_Left	
	Document Type DRAW/ELSY	Release Status Released
	Document No 8889755035	Edited October/19/2021
	Issue 007	Page No 64/83

6A4 Power Door Rear Right

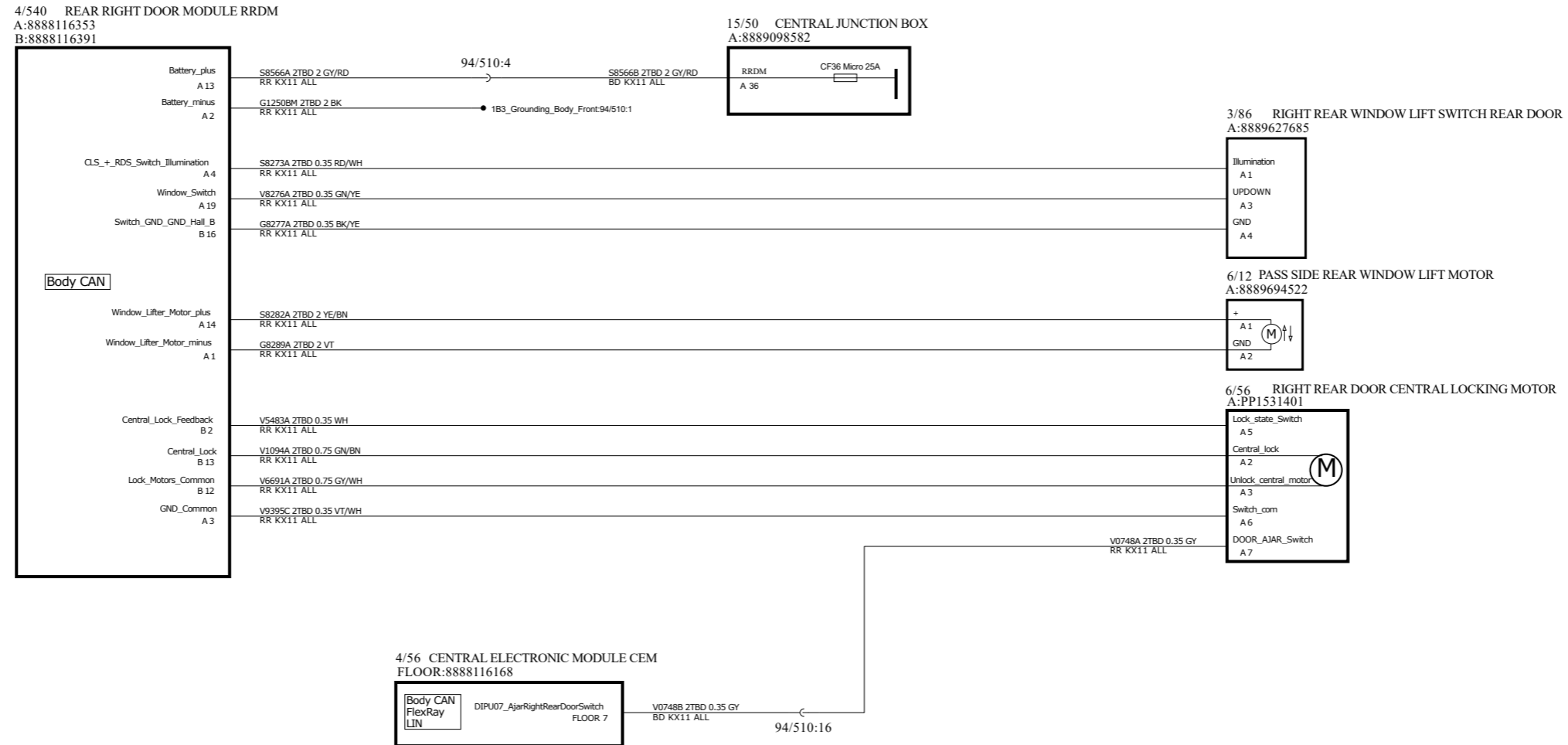

<p>The copying, distribution and utilization of this document as well as the communication of its contents to others without expressed authorization is prohibited. Offenders will be held liable for payment of damages. All rights reserved in the event of the grant of a patent, utility model or ornamental design registration.</p> <p style="text-align: center;">GEELY</p>	<p>Document title KX11_MP1_base_B7 6A4_Power_Door_Rear_Right</p>	
	<p>Document Type DRAW/ELSY</p>	<p>Release Status Released</p>
	<p>Document No 8889755035</p>	<p>Edited October/19/2021</p>
	<p>Issue 007</p>	<p>Page No 65/83</p>

6A5 Power Door Tailgate

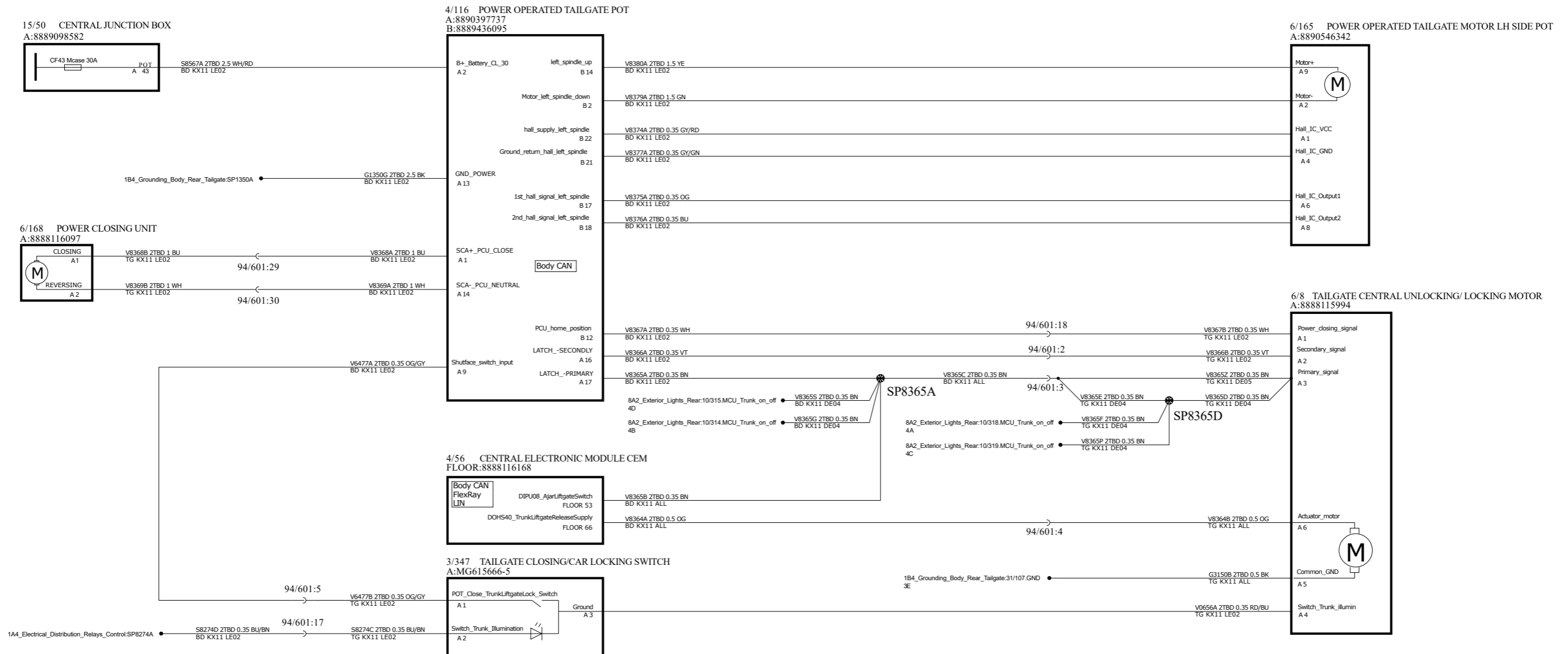

GEELY	Document title KX11_MP1_base_B7	
	6A5_Power_Door_Tailgate	
	Document Type DRAW/ELSY	Release Status Released
	Document No 8889755035	Edited December/04/2020
	Issue 007	Page No 66/83

6B Roof Manoeuvring

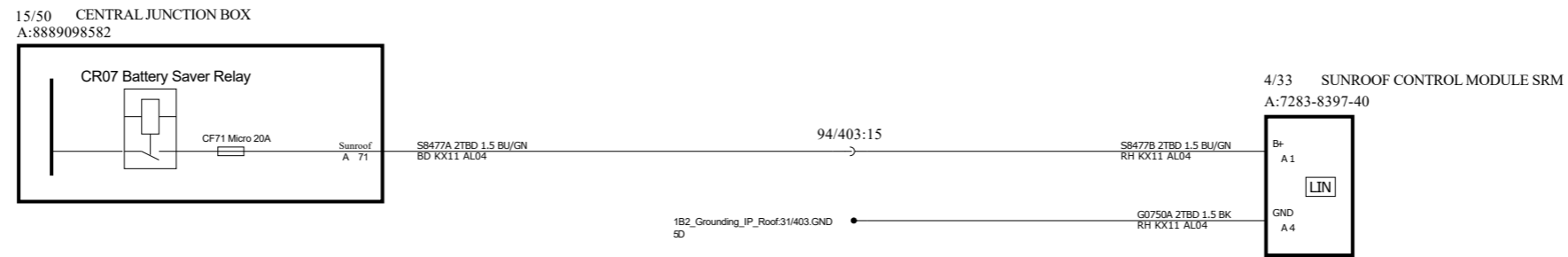

<p>The copying, distribution and utilization of this document as well as the communication of its contents to others without expressed authorization is prohibited. Offenders will be held liable for payment of damages. All rights reserved in the event of the grant of a patent, utility model or ornamental design registration.</p> <p style="text-align: center;">GEELY</p>	Document title KX11_MP1_base_B7	
	6B1_Roof_Manoeuvring	
	Document Type DRAW/ELSY	Release Status Released
	Document No 8889755035	Edited October/21/2021
Issue 007	Page No 67/83	

6B2_Roof_Manoeuvring_Internal

4/33 SUNROOF CONTROL MODULE SRM
A:7283-8397-40

B+	A 1	S8477C 2TBD 2.5 RD Int KX11 ALD4
GND	A 4	G0750BA 2TBD 2.5 BK Int KX11 ALD4
Factory_mode	A 2	V6211A 2TBD 0.75 RD Int KX11 ALD4
Lin	A 10	L6135BA 2TBD 0.5 GN/WH Int KX11 ALD4
Glass_tilt	A 7	V6217A 2TBD 0.5 GN Int KX11 ALD4
Glass_open	A 5	V6218A 2TBD 0.5 BN/BK Int KX11 ALD4
Glass_close	A 6	V6219A 2TBD 0.5 YE Int KX11 ALD4
Roll_open	A 8	V6221A 2TBD 0.5 BN Int KX11 ALD4
Roll_close	A 9	V6222A 2TBD 0.5 BU Int KX11 ALD4

6/15 SUNROOF MOTOR
A:7283-5843-40

B+	A 1
GND	A 11
Factory_mode	A 3
Lin	A 14
Glass_tilt	A 15
Glass_open	A 5
Glass_close	A 6
Roll_open	A 7
Roll_close	A 16
Hall_GND	A 8
Hall_power_supply	A 9
Hall_2	A 19
Hall_1	A 18
M+	A 20
M-	A 10

6/230 GLASS ROOF PANEL BLIND MOTOR
A:BAUT0416-P001

M-	A 1
M+	A 2
Hall_1	A 3
Hall_2	A 5
Hall_power_supply	A 6
Hall_GND	A 4

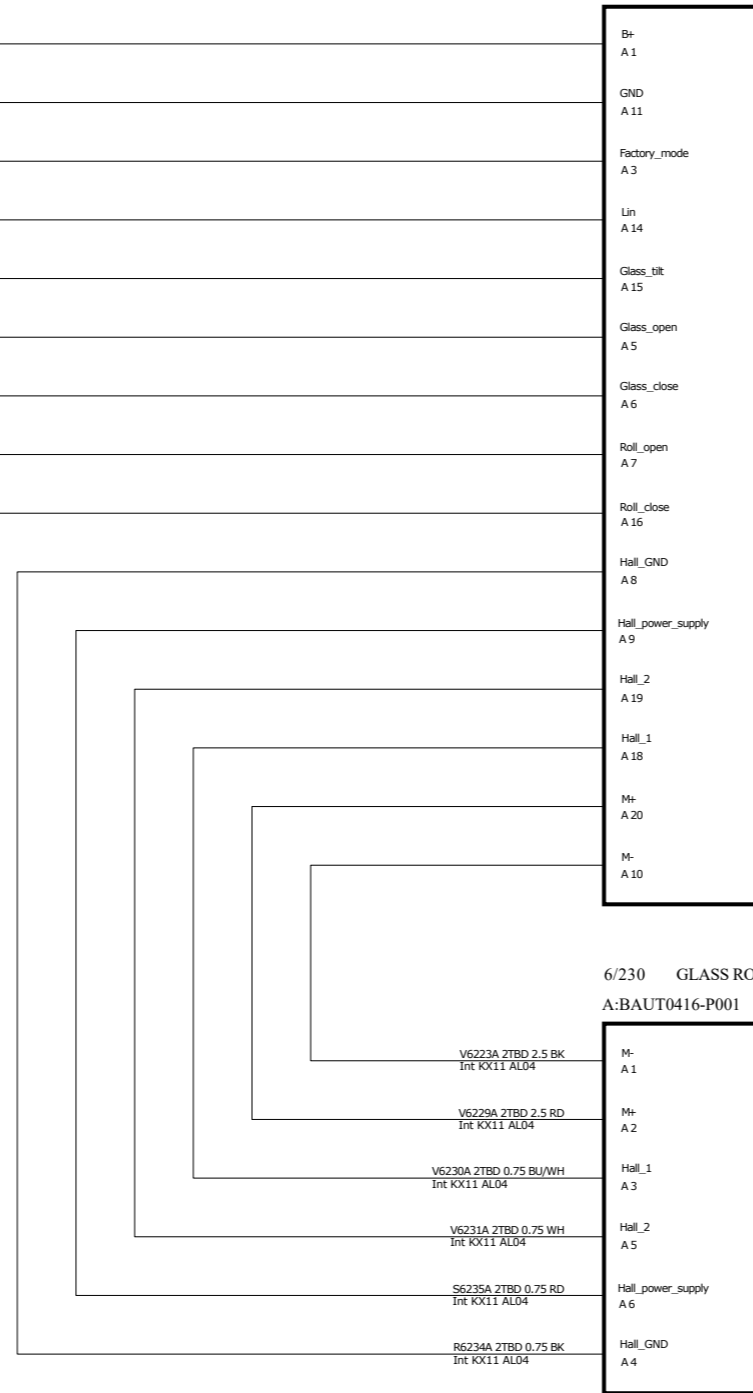

<p>The copying, distribution and utilization of this document as well as the communication of its contents to others without expressed authorization is prohibited. Offenders will be held liable for payment of damages. All rights reserved in the event of the grant of a patent, utility model or ornamental design registration.</p> <p style="text-align: center; font-size: 24pt; font-weight: bold;">GEELY</p>	<p>Document title KX11_MP1_base_B7 6B2_Roof_Manoeuvring_Internal</p>	
	<p>Document Type DRAW/ELSY</p>	<p>Release Status Released</p>
	<p>Document No 8889755035</p>	<p>Edited October/21/2021</p>
	<p>Issue 007</p>	<p>Page No 68/83</p>

6C1 Windscreen Defroster Control

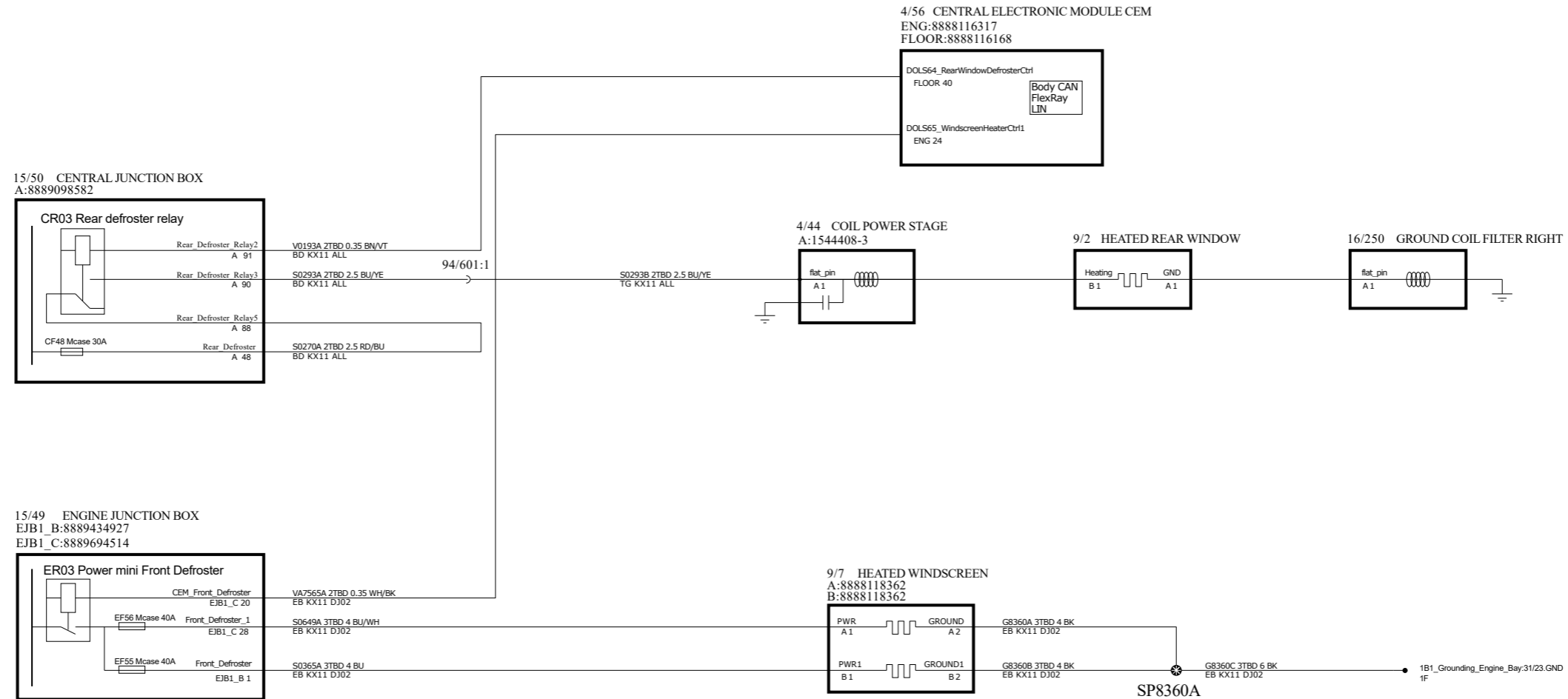

<p>The copying, distribution and utilization of this document as well as the communication of its contents to others without expressed authorization is prohibited. Offenders will be held liable for payment of damages. All rights reserved in the event of the grant of a patent, utility model or ornamental design registration.</p> <p style="text-align: center;">GEELY</p>	<p>Document title KX11_MP1_base_B7</p> <p>6C1_Windscreen_Defroster_Control</p>	
	<p>Document Type DRAW/ELSY</p>	<p>Release Status Released</p>
	<p>Document No 8889755035</p>	<p>Edited December/04/2020</p>
	<p>Issue 007</p>	<p>Page No 69/83</p>

6C2 Windscreen Cleaning Control

15/49 ENGINE JUNCTION BOX
 EJB1_B:8889434927
 EJB1_C:8889694514
 EJB1_D:8889694512

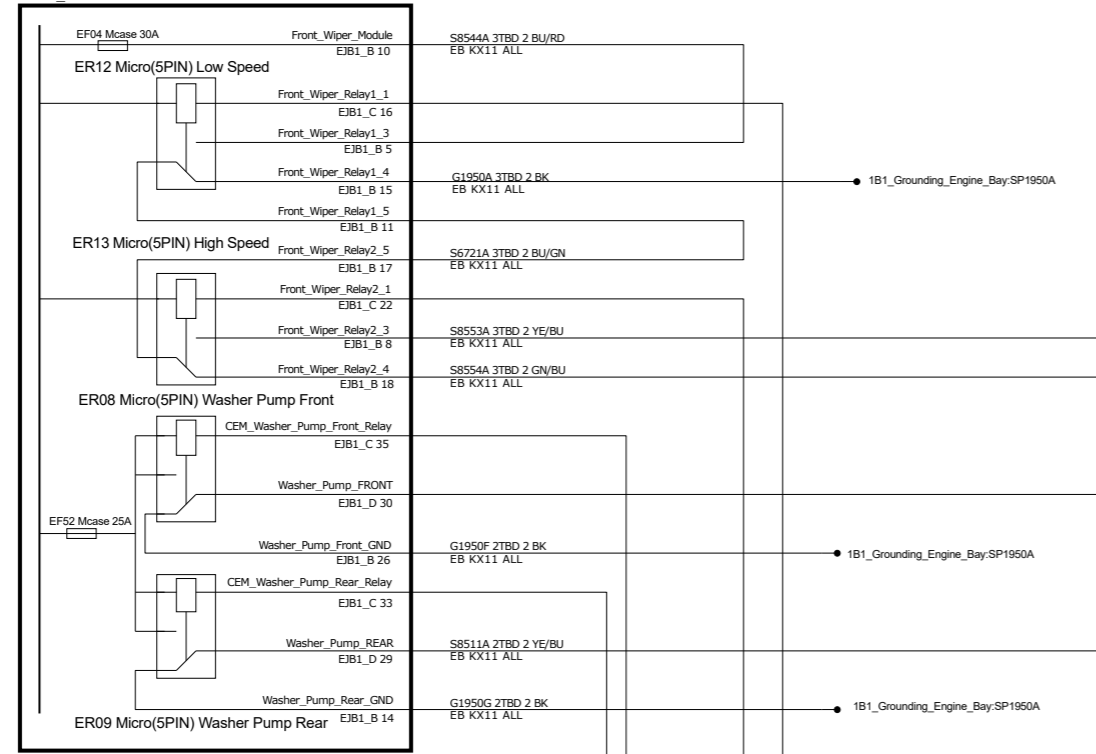

4/56 CENTRAL ELECTRONIC MODULE CEM
 ENG:8888116317
 FLOOR:8888116168

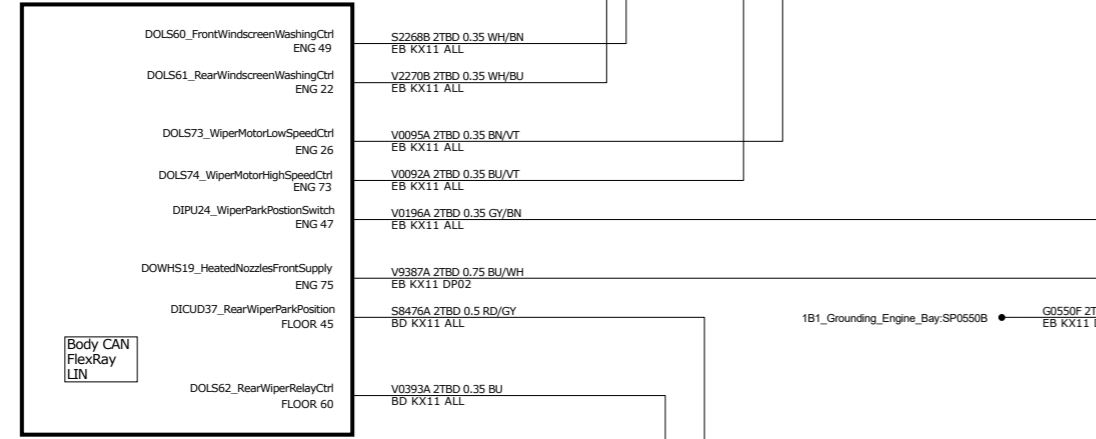

15/50 CENTRAL JUNCTION BOX
 A:8889098582

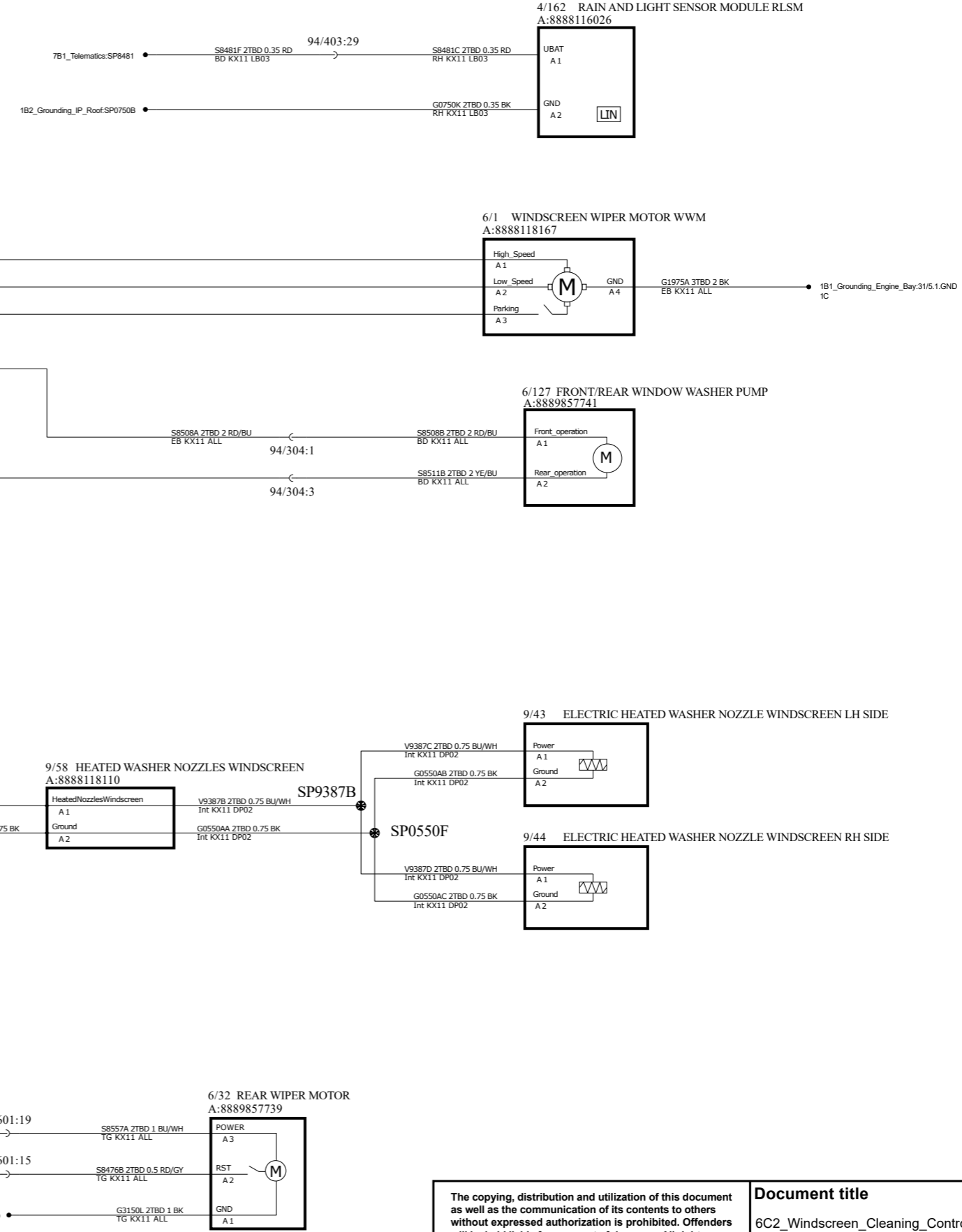
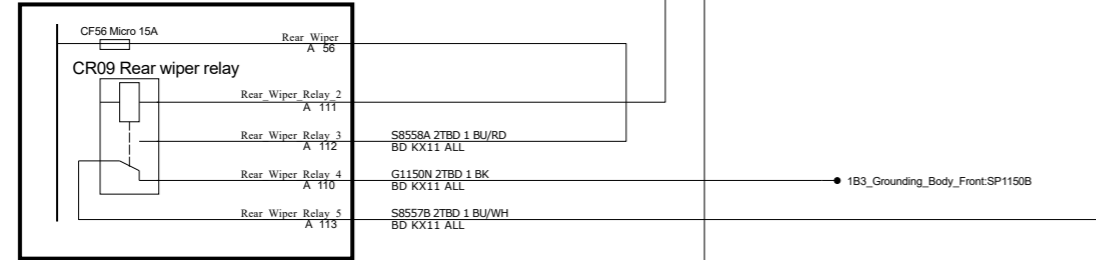

<p>The copying, distribution and utilization of this document as well as the communication of its contents to others without expressed authorization is prohibited. Offenders will be held liable for payment of damages. All rights reserved in the event of the grant of a patent, utility model or ornamental design registration.</p>		<p>Document title KX11_MP1_base_B7 6C2_Windscreen_Cleaning_Control</p>	
		<p>Document Type DRAW/ELSY</p>	<p>Release Status Released</p>
<p>GEELY</p>		<p>Document No 8889755035</p>	<p>Edited April/16/2021</p>
		<p>Issue 007</p>	<p>Page No 70/83</p>

6D Voltage Outlet

15/50 CENTRAL JUNCTION BOX
A:8889098582

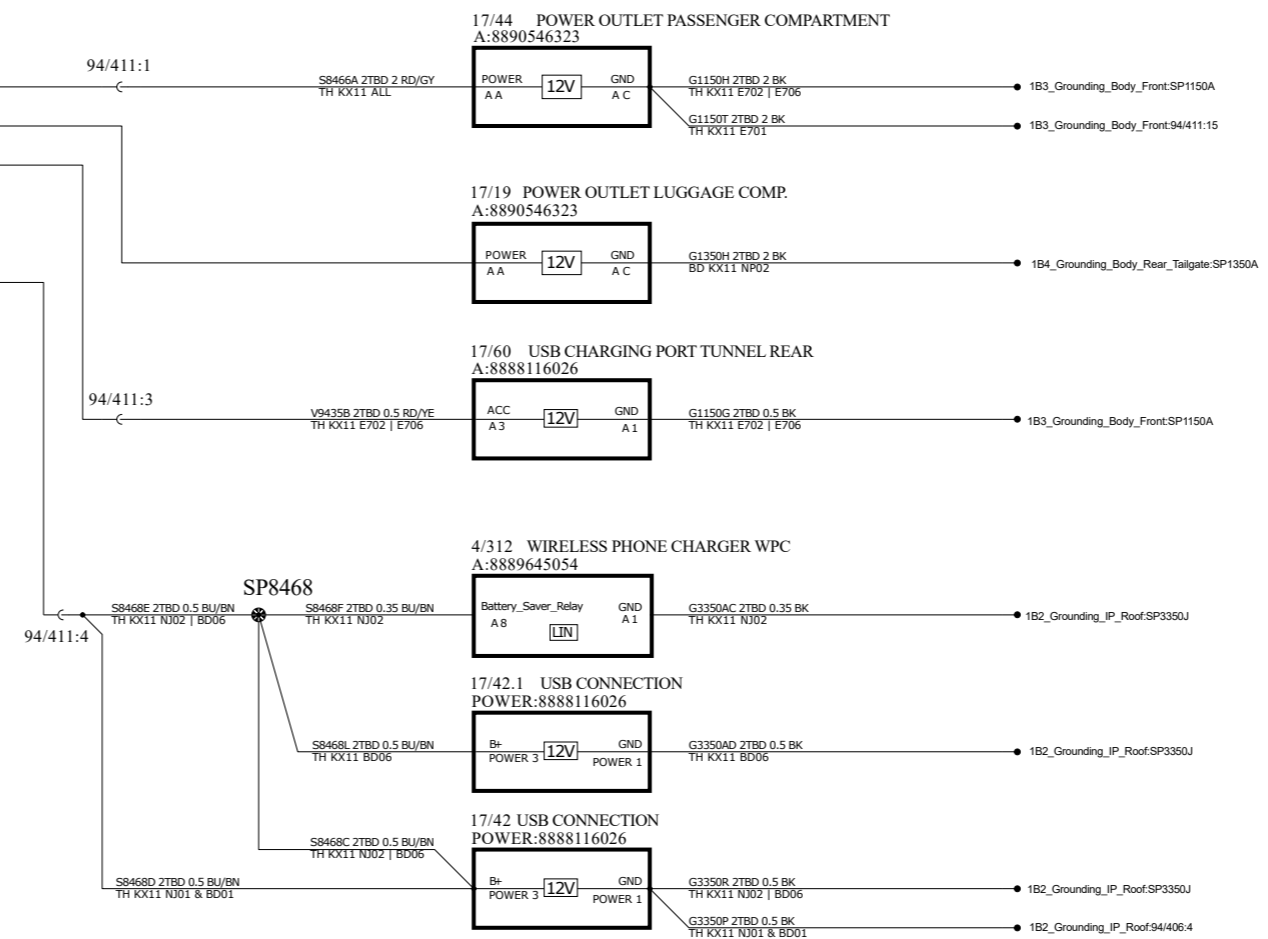
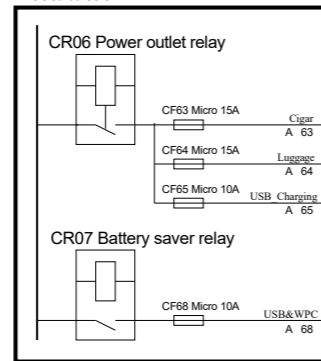

GEELY	Document title KX11_MP1_base_B7	
	6D_Voltage_Outlet	
	Document Type DRAW/ELSY	Release Status Released
	Document No 8889755035	Edited October/19/2021
	Issue 007	Page No 71/83

6E Steering Wheel

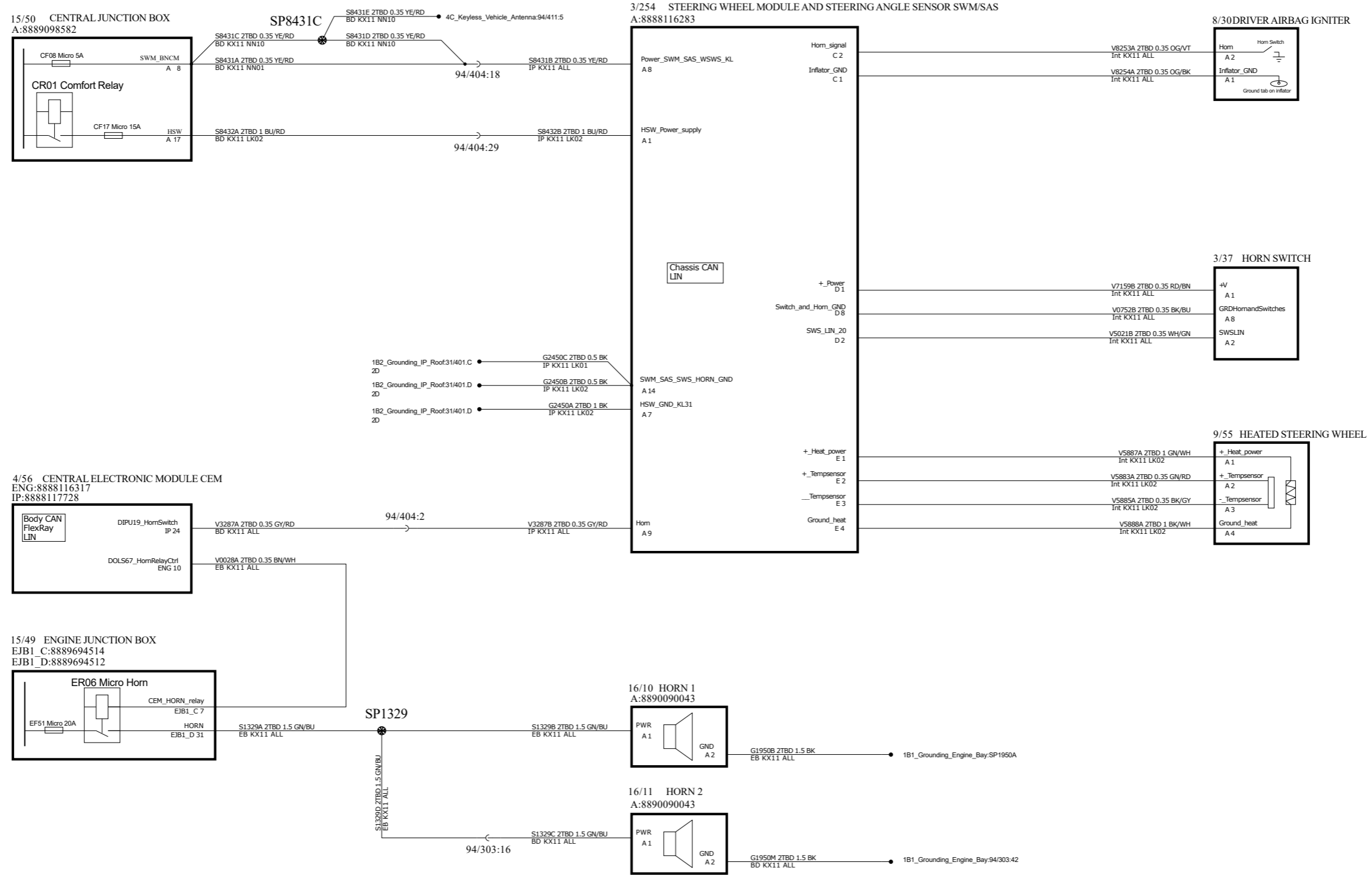

GEELY	Document title KX11_MP1_base_B7	
	6E_Steering_Wheel	
	Document Type DRAW/ELSY	Release Status Released
	Document No 8889755035	Edited December/04/2020
	Issue 007	Page No 72/83

6F Accessories

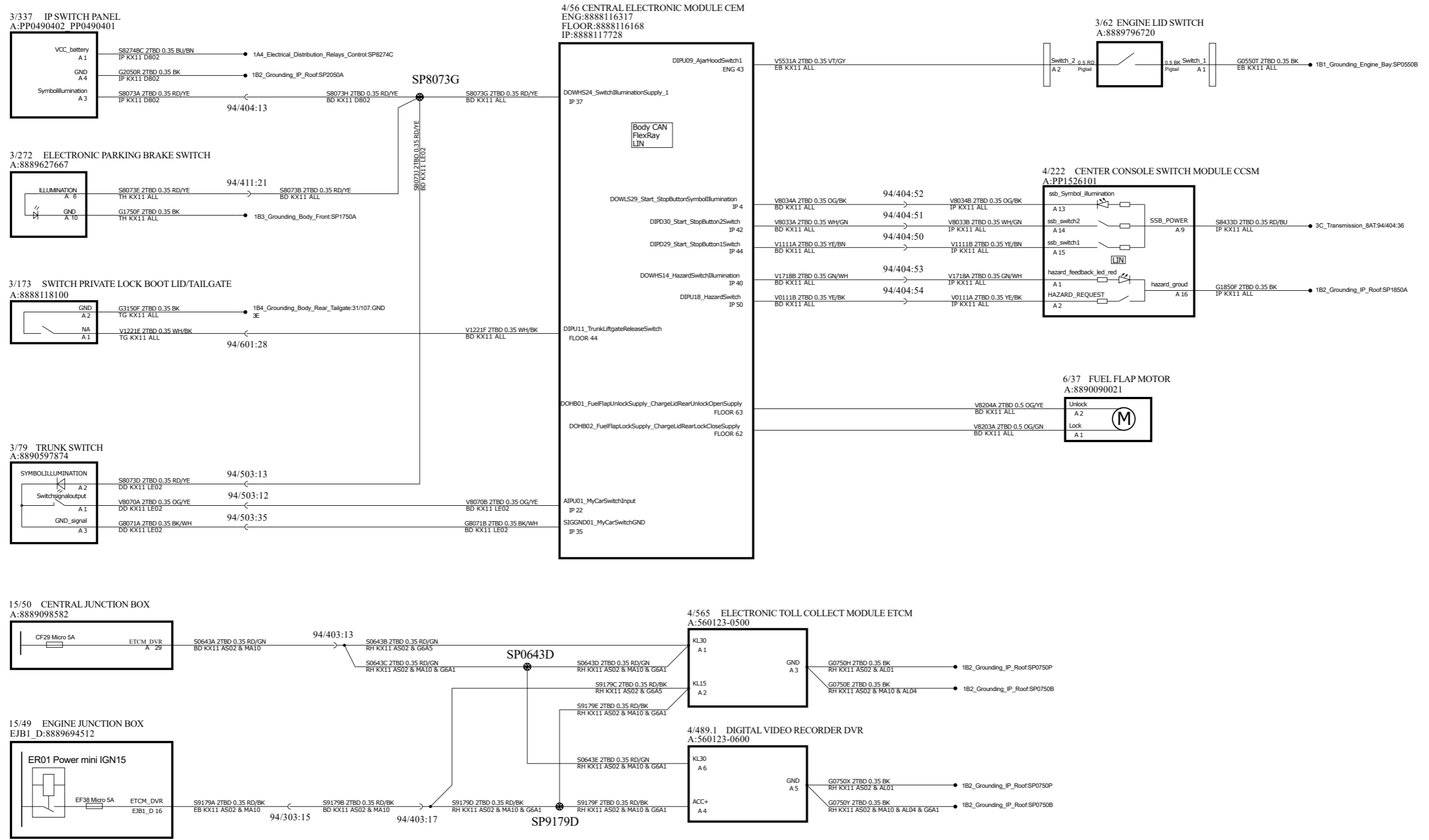

<p>The copying, distribution and utilization of this document as well as the communication of its contents to others without expressed authorization is prohibited. Offenders will be held liable for payment of damages. All rights reserved in the event of the grant of a patent, utility model or ornamental design registration.</p> <h2 style="margin: 0;">GEELY</h2>	Document title KX11_MP1_base_B7 6F_Accessories	
	Document Type DRAW/ELSY	Release Status Released
	Document No 8889755035	Edited October/19/2021
	Issue 007	Page No 73/83

7A1 External Amplifier

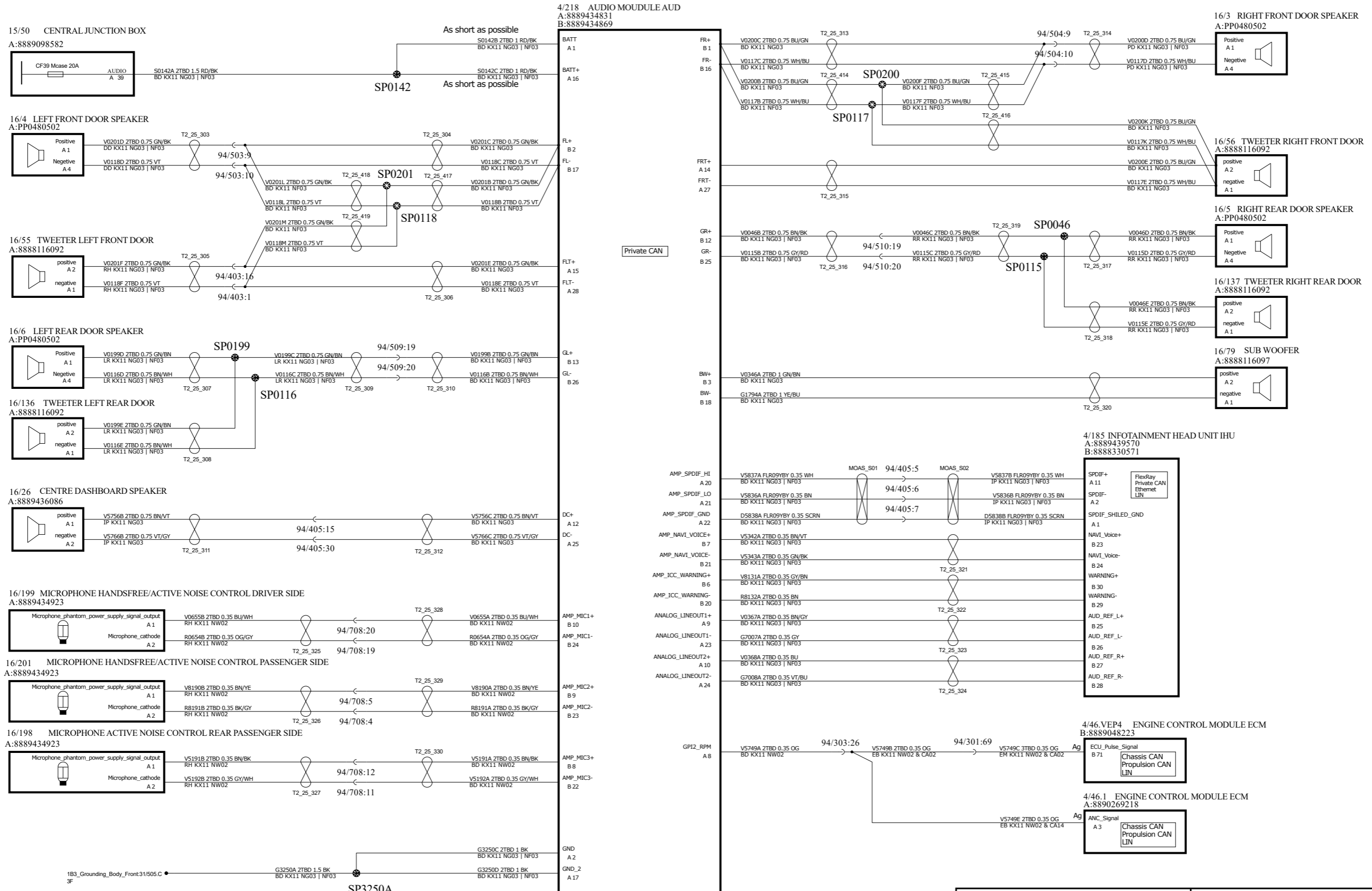

<p>The copying, distribution and utilization of this document as well as the communication of its contents to others without expressed authorization is prohibited. Offenders will be held liable for payment of damages. All rights reserved in the event of the grant of a patent, utility model or ornamental design registration.</p>		Document title KX11_MP1_base_B7	
		7A1_External_Amplifier	
Document Type DRAW/ELSY		Release Status Released	
Document No 8889755035		Edited June/18/2021	
Issue 007		Page No 74/83	

GEELY

7A2 Infotainment

4/185 INFOTAINMENT HEAD UNIT IHU
 A:8889439570
 B:8888330571
 CSD:8888116304
 PSD:8888116298
 USB:8889439617
 TUNER:8889435914

15/50 CENTRAL JUNCTION BOX
 A:8889098582

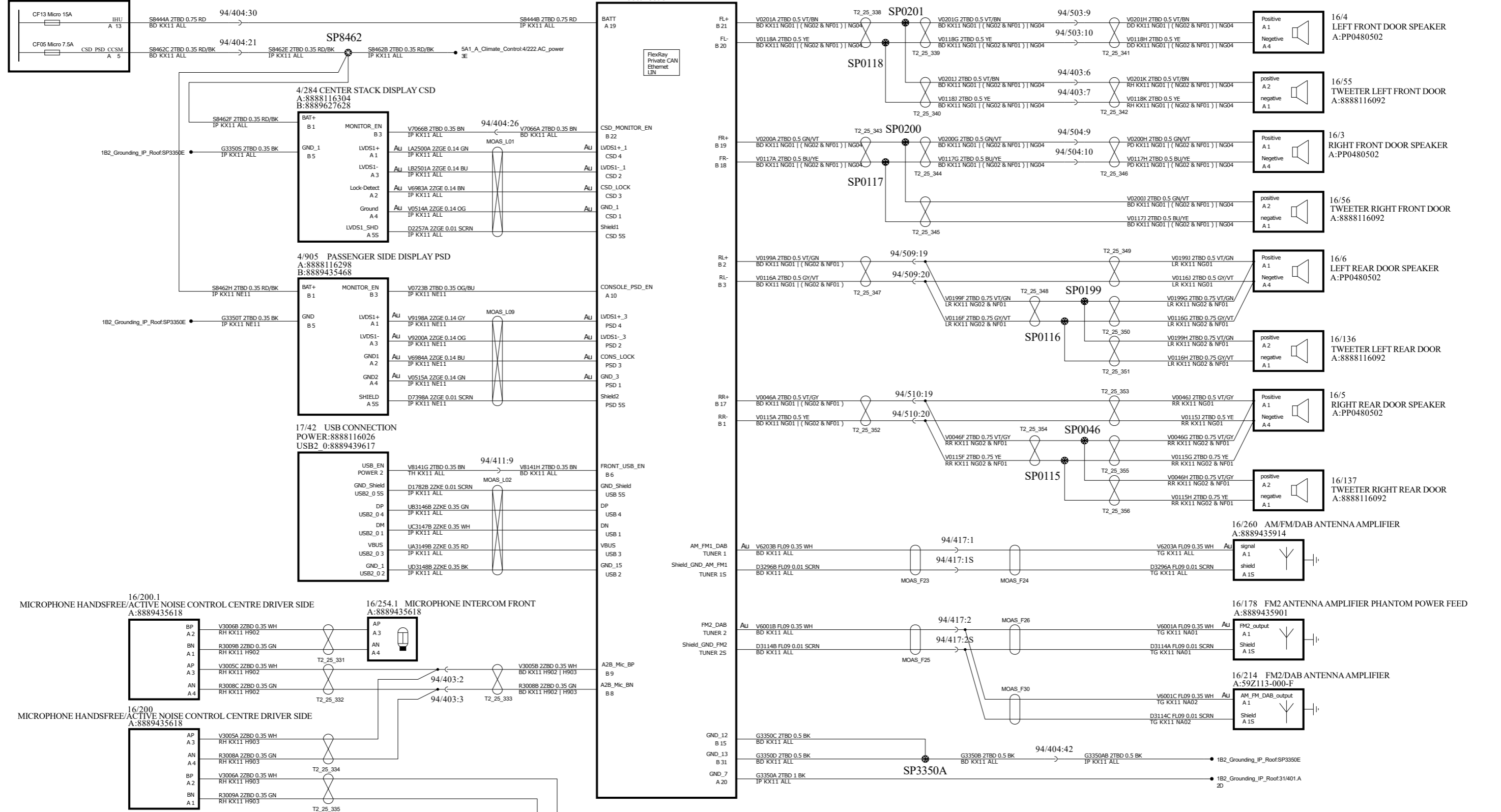

The copying, distribution and utilization of this document as well as the communication of its contents to others without expressed authorization is prohibited. Offenders will be held liable for payment of damages. All rights reserved in the event of the grant of a patent, utility model or ornamental design registration.		Document title 7A2_Infotainment		KX11_MP1_base_B7	
Document Type DRAW/ELSY		Release Status Released			
Document No 8889755035		Edited October/19/2021			
Issue 007		Page No 75/83			

GEELY

7B1 Telematics

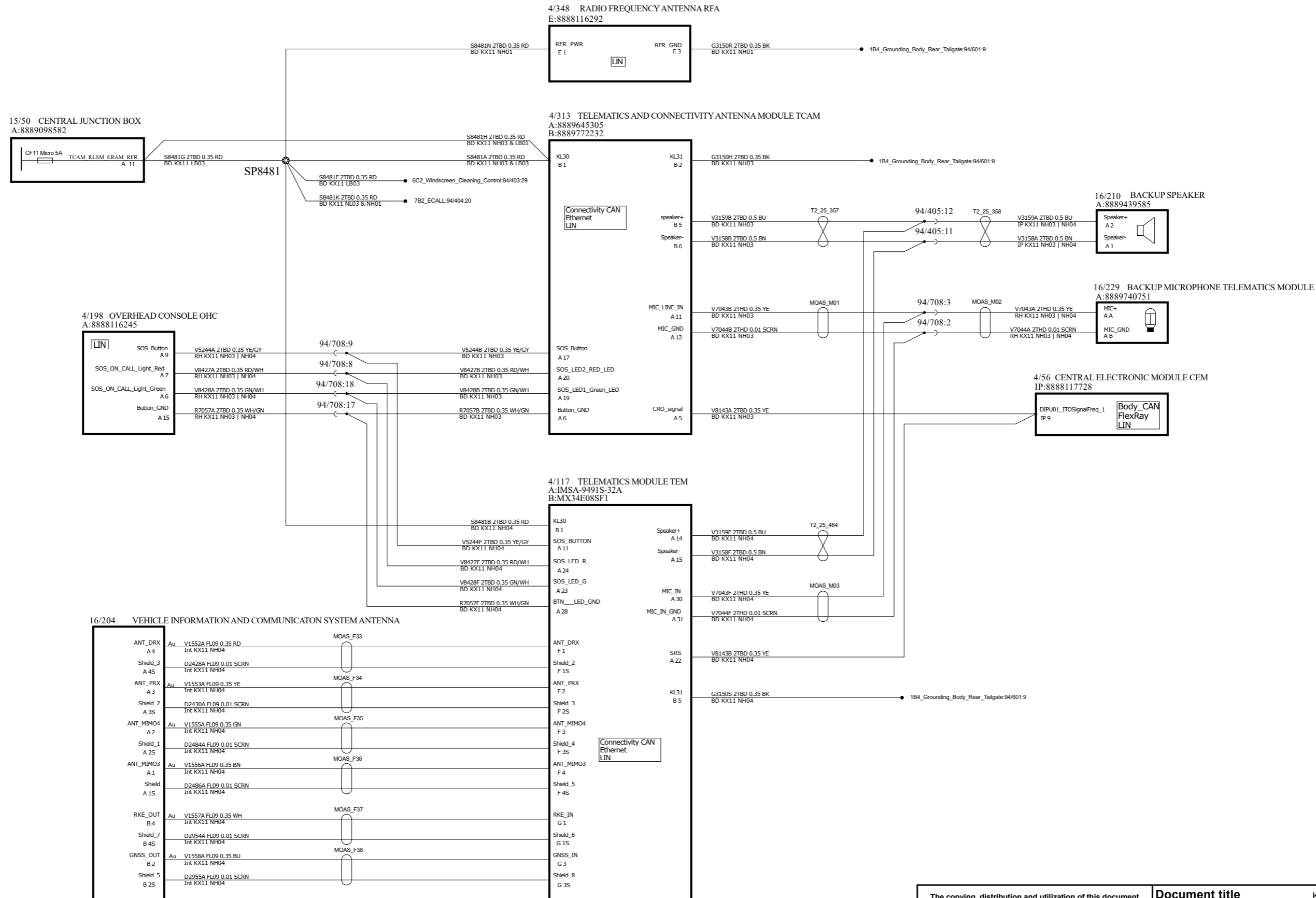

GEELY	Document title KX11_MP1_base_B7	
	7B1_Telematics	
	Document Type DRAW/ELSY	Release Status Released
	Document No 8889755035	Edited April/16/2021
	Issue 007	Page No 76/83

7B2 ECALL

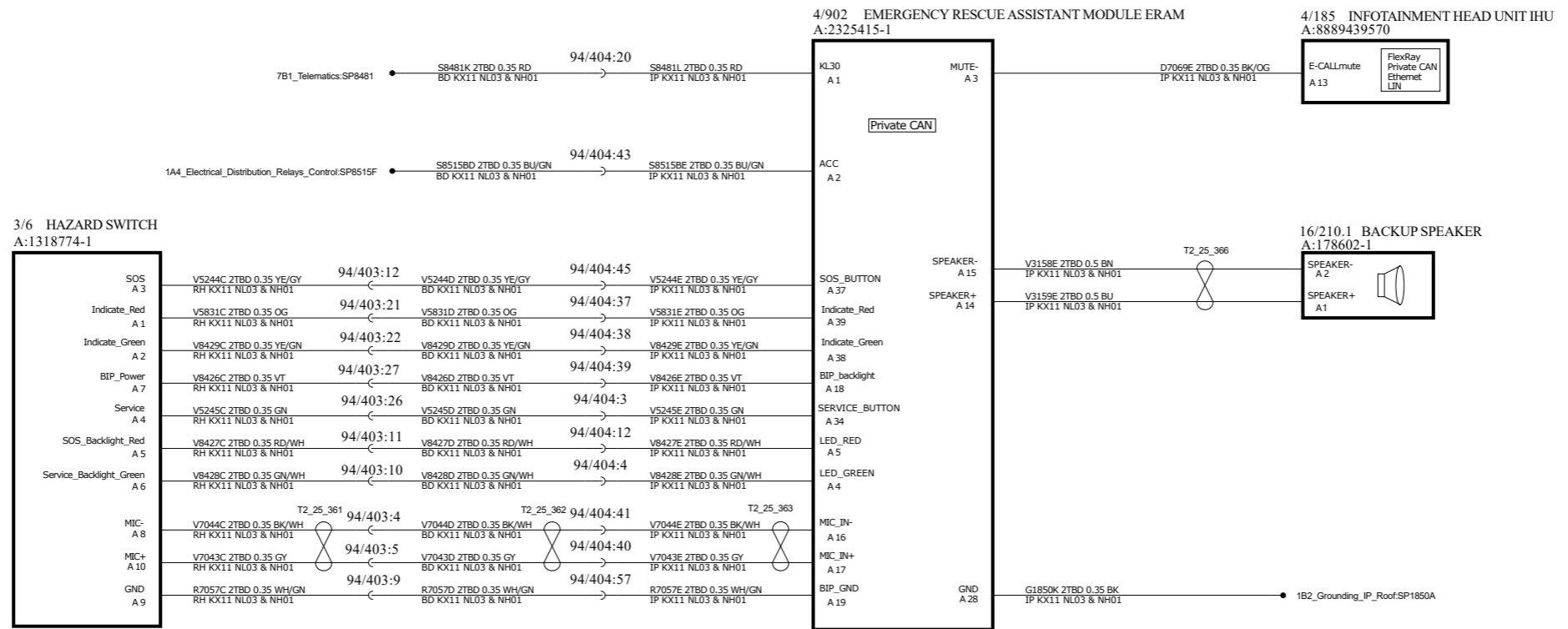

<p>The copying, distribution and utilization of this document as well as the communication of its contents to others without expressed authorization is prohibited. Offenders will be held liable for payment of damages. All rights reserved in the event of the grant of a patent, utility model or ornamental design registration.</p> <h2 style="margin: 0;">GEELY</h2>	Document title KX11_MP1_base_B7 7B2_ECALL	
	Document Type DRAW/ELSY	Release Status Released
	Document No 8889755035	Edited September/27/2021
	Issue 007	Page No 77/83

7C Display

15/50 CENTRAL JUNCTION BOX
A:8889098582

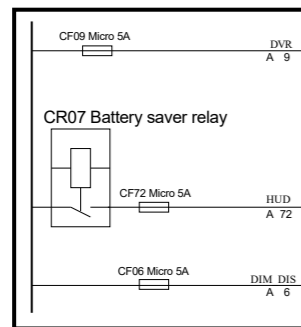

4/489 DIGITAL VIDEO RECORDER DVR
A:8889435468
TO_CAMERA:8889435914

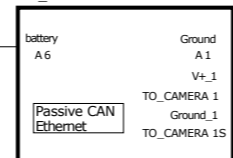

27/44 VIDEO RECORD CAMERA
A:59Z143-000-A

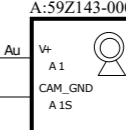

4/487 DRIVER INFORMATION SCREEN DIS
A:8889435468
BOX_HSD:8889857779

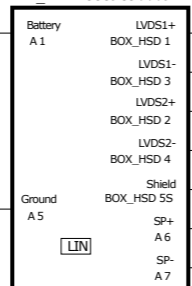

4/223 DRIVER INFORMATION MODULE DIM
A:8889694506
DIS_HSD:8888116298
HUD_HSD:8888116300
IHU_HSD:8888116308

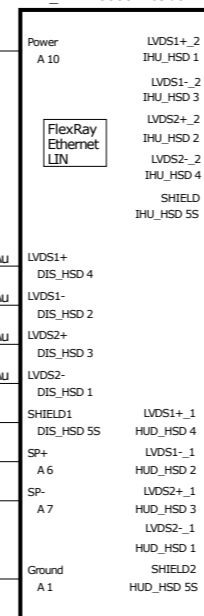

4/185 INFOTAINMENT HEAD UNIT IHU
DIM:8889124290

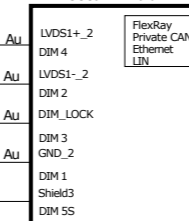

4/228 HEAD UP DISPLAY HUD
A:8889627650
B:8888116298

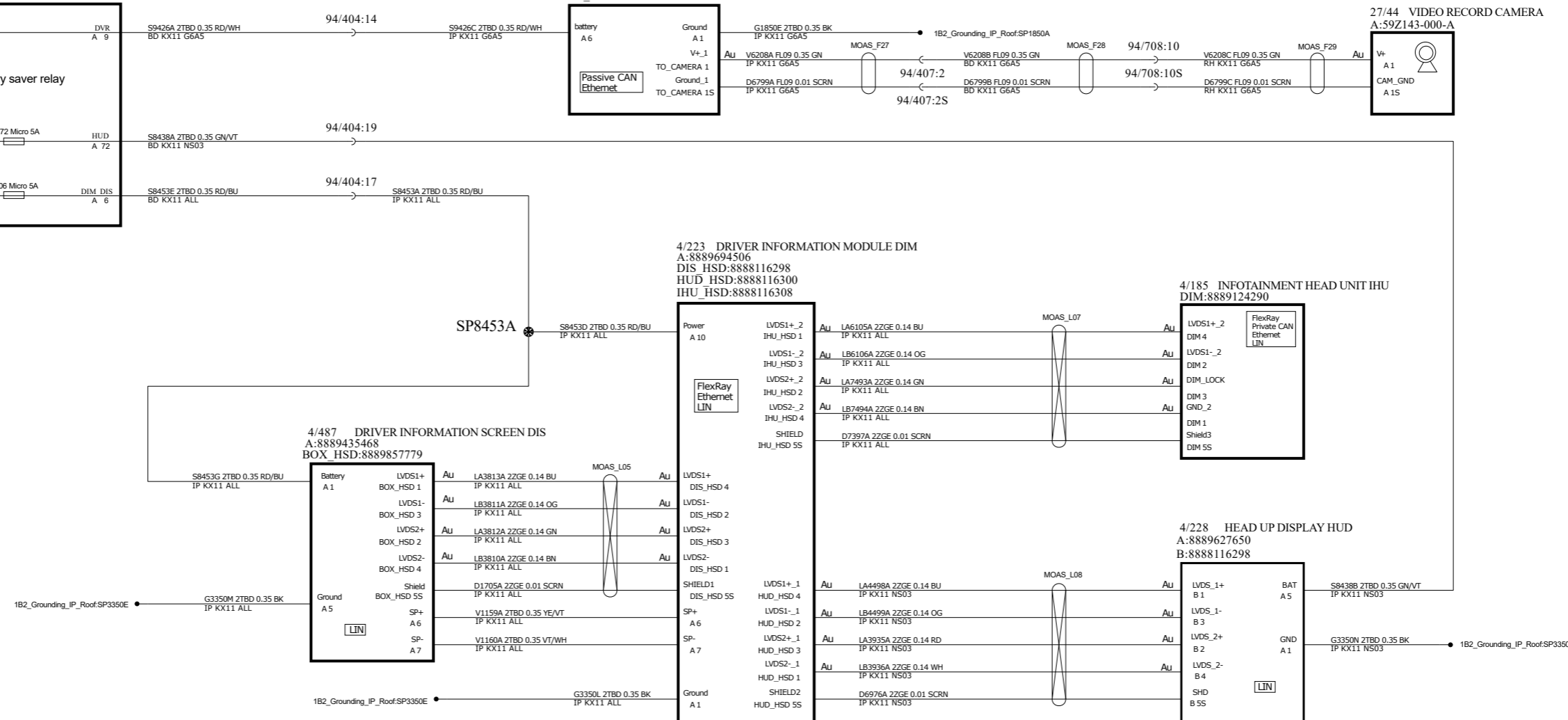
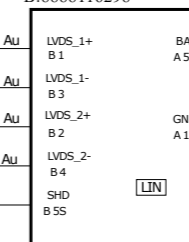

GEELY	The copying, distribution and utilization of this document as well as the communication of its contents to others without expressed authorization is prohibited. Offenders will be held liable for payment of damages. All rights reserved in the event of the grant of a patent, utility model or ornamental design registration.		Document title KX11_MP1_base_B7	
			7C_Display	
	Document Type DRAW/ELSY	Release Status Released		
	Document No 8889755035	Edited March/02/2021		Page No 78/83
	Issue 007			

8A1 Exterior Lights Front

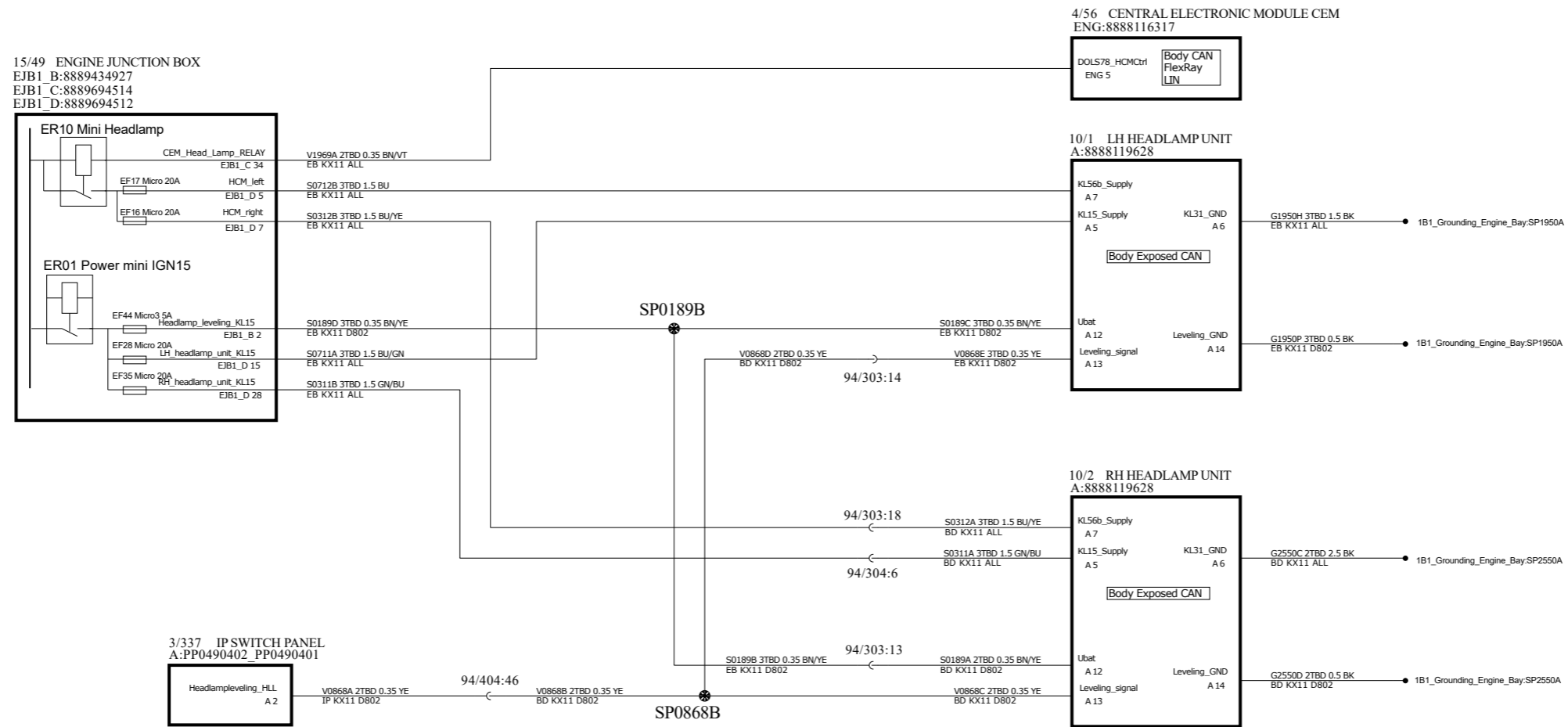

<p>The copying, distribution and utilization of this document as well as the communication of its contents to others without expressed authorization is prohibited. Offenders will be held liable for payment of damages. All rights reserved in the event of the grant of a patent, utility model or ornamental design registration.</p> <p style="text-align: center; font-size: 24pt; font-weight: bold;">GEELY</p>	Document title KX11_MP1_base_B7 8A1_Exterior_Lights_Front	
	Document Type DRAW/ELSY	Release Status Released
	Document No 8889755035	Edited May/24/2021
	Issue 007	Page No 79/83

8A2 Exterior Lights Rear

4/56 CENTRAL ELECTRONIC MODULE CEM
 ROOF:8888115940
 ENG:8888116317
 IP:8888117728
 FLOOR:8888116168

7/124 BRAKE PEDAL SENSOR
 A:8888117752

15/49 ENGINE JUNCTION BOX
 EJB1 B:8889434927

15/50 CENTRAL JUNCTION BOX
 A:8889098582

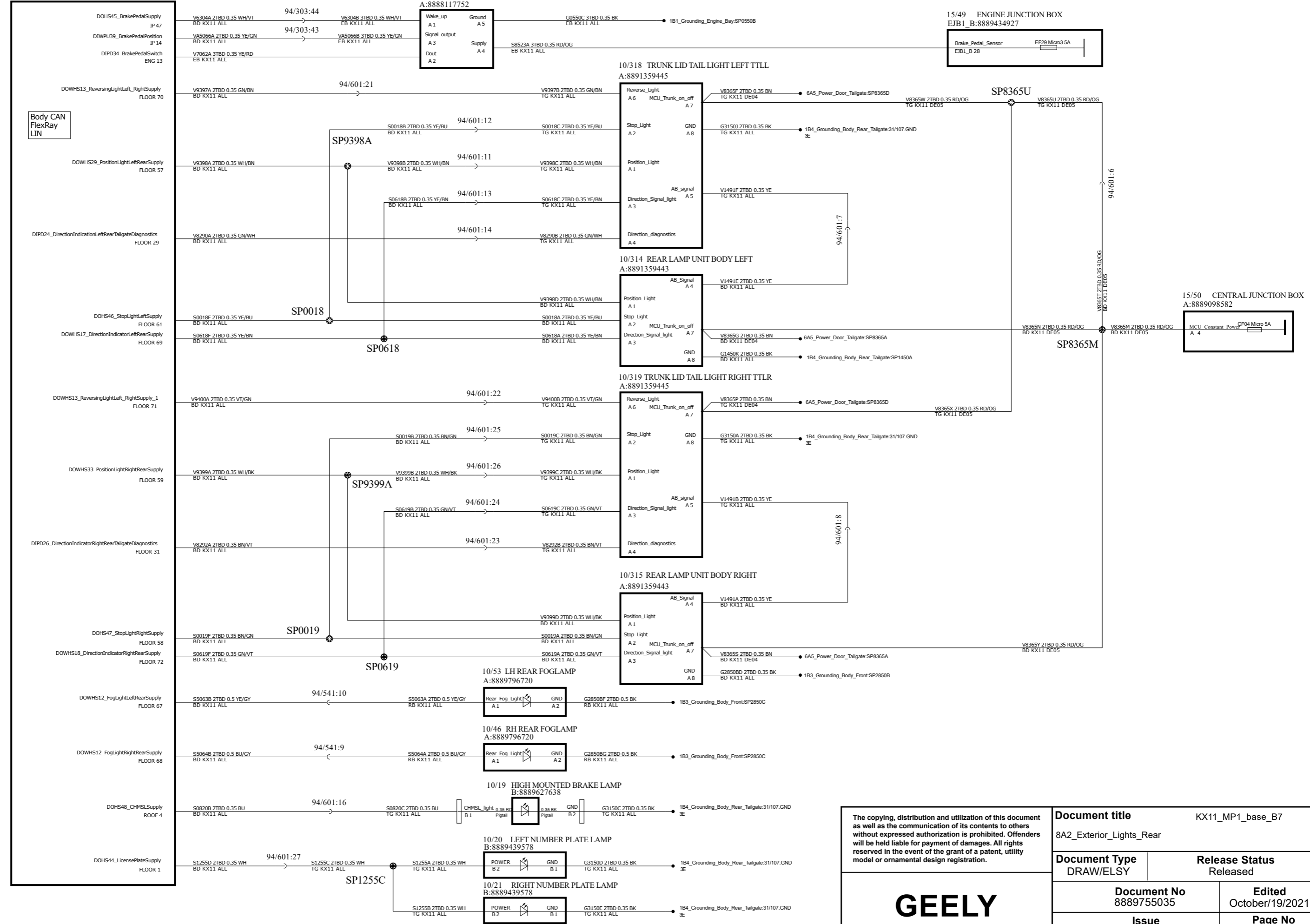

<p>The copying, distribution and utilization of this document as well as the communication of its contents to others without expressed authorization is prohibited. Offenders will be held liable for payment of damages. All rights reserved in the event of the grant of a patent, utility model or ornamental design registration.</p>		<p>Document title KX11_MP1_base_B7</p>	
		<p>8A2_Exterior_Lights_Rear</p>	
<p>Document Type DRAW/ELSY</p>		<p>Release Status Released</p>	
<p>Document No 8889755035</p>		<p>Edited October/19/2021</p>	
<p>Issue 007</p>		<p>Page No 80/83</p>	

GEELY

8B1 Interior Lights Overhead

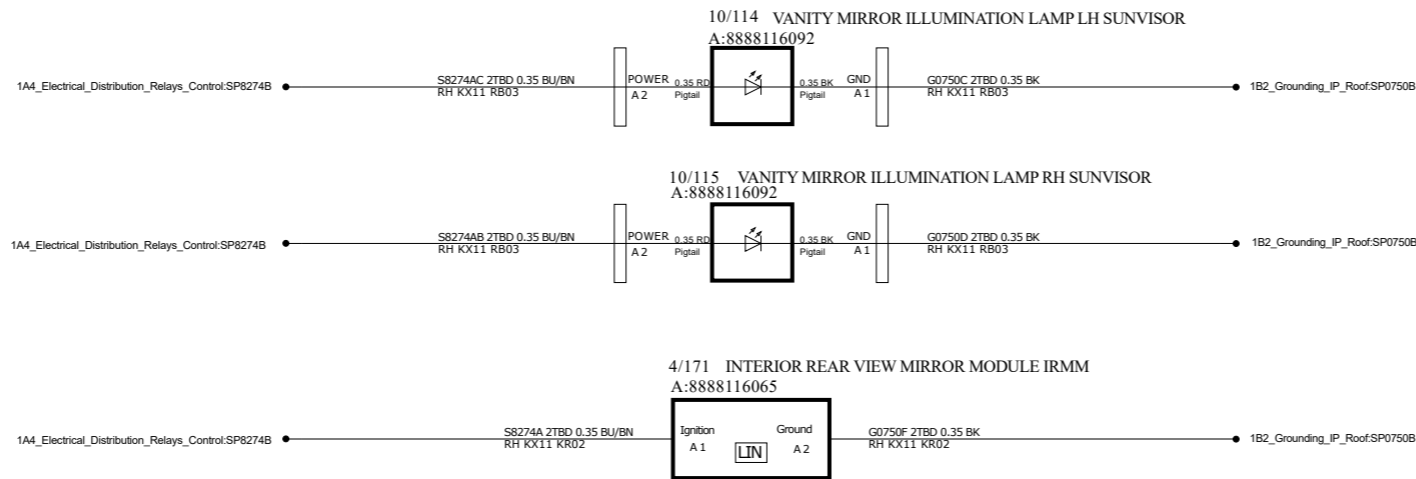
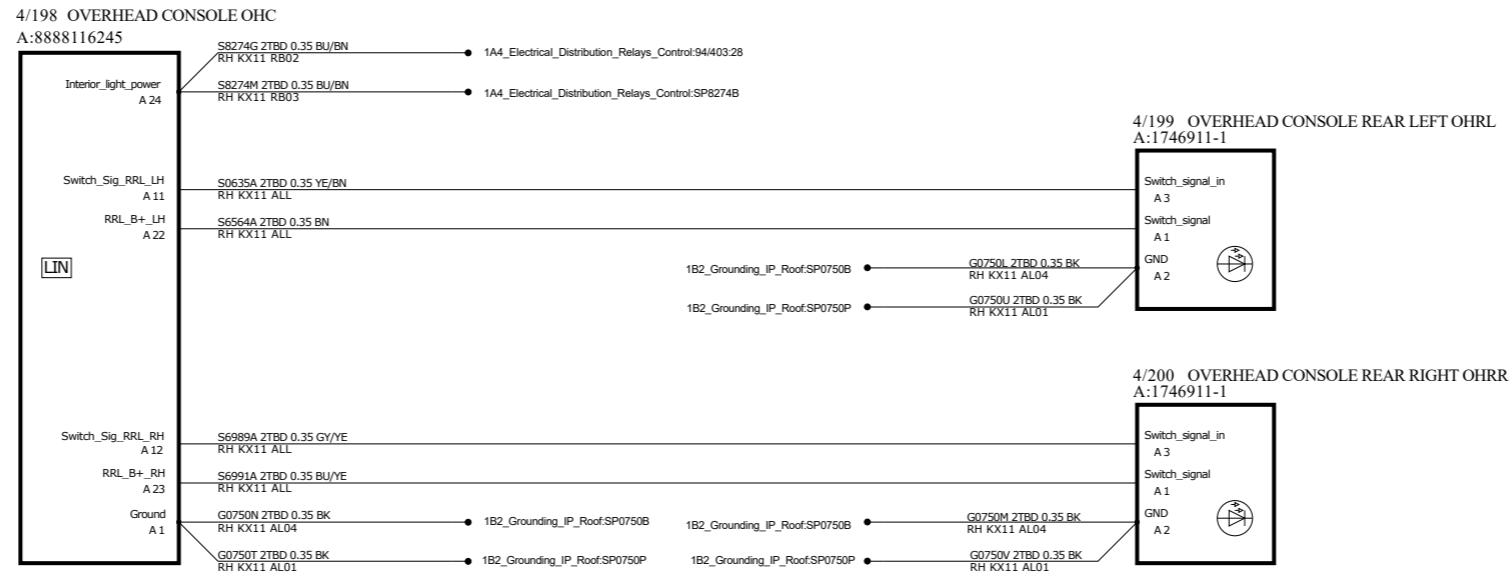

<p>The copying, distribution and utilization of this document as well as the communication of its contents to others without expressed authorization is prohibited. Offenders will be held liable for payment of damages. All rights reserved in the event of the grant of a patent, utility model or ornamental design registration.</p> <p style="text-align: center; font-size: 24pt; font-weight: bold;">GEELY</p>	Document title KX11_MP1_base_B7 8B1_Interior_Lights_Overhead	
	Document Type DRAW/ELSY	Release Status Released
	Document No 8889755035	Edited December/04/2020
	Issue 007	Page No 81/83

8B2 Interior Lights Ambient

4/56 CENTRAL ELECTRONIC MODULE CEM
 FLOOR:8888116168
 IP:8888117728

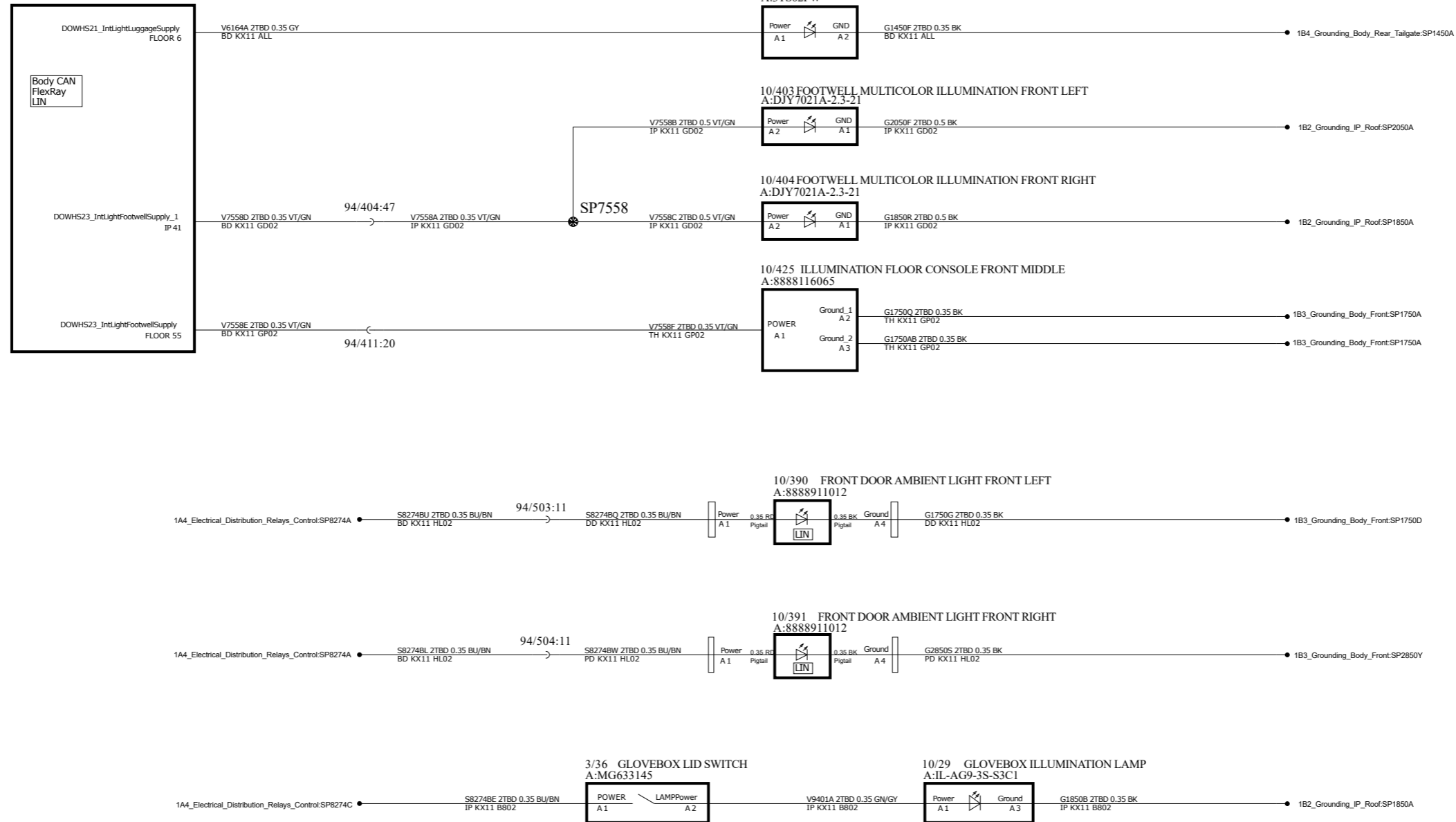

GEELY	Document title KX11_MP1_base_B7 8B2_Interior_Lights_Ambient	
	Document Type DRAW/ELSY	Release Status Released
	Document No 8889755035	Edited October/19/2021
	Issue 007	Page No 82/83

9C Energy Management High Voltage

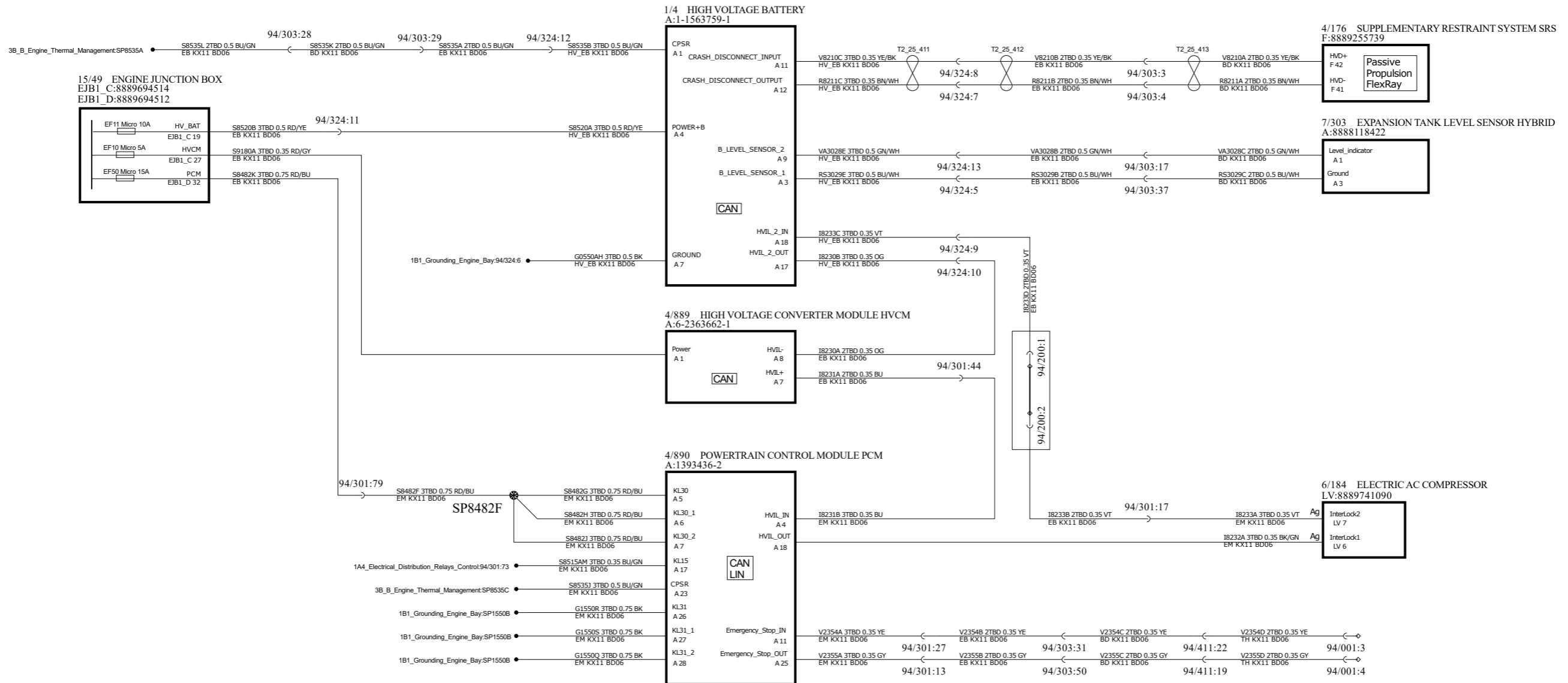

GEELY	Document title KX11_MP1_base_B7 9C_Energy_Management_High_Voltage	
	Document Type DRAW/ELSY	Release Status Released
	Document No 8889755035	Edited May/27/2021
	Issue 007	Page No 83/83